

3

Independent Assortment of Genes

WORKING WITH THE FIGURES

1. Using Table 3-1, answer the following questions:
 - a. If χ^2 is calculated to be 17 with 9 df, what is the approximate probability value?
 - b. If χ^2 is 17 with 6 df, what is the probability value?
 - c. What trend (“rule”) do you see in the previous two calculations?

Answer:

- a. For 9 degrees of freedom, with this value probability (p) is between 0.05 and 0.025
 - b. For 6 degrees of freedom, with the same chi-square value, probability is between 0.01 and 0.005
 - c. We could see that critical chi-square values differ depending on the number of categories (proportional to the “df”) and with fewer categories, a statistical test yields a lower probability of the null hypothesis
2. Inspect Figure 3-8: which meiotic stage is responsible for generating Mendel’s second law?

Answer: Anaphase I, when homologous chromosomes independently assort from the equatorial plane in the metaphase I.

3. In Figure 3-9,
 - a. identify the diploid nuclei.
 - b. identify which part of the figure illustrates Mendel’s first law.

Answer:

- a. Diploid nuclei could be found in the diploid meiocytes, just before

meiosis.

b. Mendel's first law of the segregation is best illustrated in ascus (pl., asci) formation, where alleles from diploid meiocytes are distributed in the haploid sexual spores (ascospore).

4. Inspect Figure 3-10: what would be the outcome in the octad if on rare occasions a nucleus from the postmeiotic mitotic division of nucleus 2 slipped past a nucleus from the postmeiotic mitotic division of nucleus 3? How could you measure the frequency of such a rare event?

Answer: In Figure 3-10, the four spore pairs (1-4) would change the number of nuclei per ascospore, so that the middle pair has one spore with no nuclei and one with 2. This would be easy to detect using micro-dissection of the large spore sample and calculating the frequency of such events.

5. In Figure 3-11, if the input genotypes were $a \cdot B$ and $A \cdot b$, what would be the genotypes colored blue?

Answer: Recombinant genotypes would be: AB and ab .

6. In Figure 3-13, what are the origins of the chromosomes colored dark blue, light blue, and very light blue?

Answer: Dark blue chromosome comes from the parent with dominant homozygous genotype for an allele B , while light blue comes from the parent with a recessive homozygous genotype for the allele b . Very light blue chromosome also carries a recessive allele, but this chromosome comes from a testcross individual in F_1 generation.

7. In Figure 3-17, in which bar of the histogram would the genotype $R_1/r_1 \cdot R_2/R_2 \cdot r_3/r_3$ be found?

Answer: This genotype has three dominant alleles (doses) and belongs to the middle part of the histogram (with value of 20).

8. In examining Figure 3-19, what do you think is the main reason for the difference in size of yeast and human mtDNA?

Answer: Yeast and human DNA differ in size probably because of their evolutionary distance. Yeast mitochondria have 78kb, yet most are nongenic DNA, while human mitochondria have only about 17kb, with energy-producing and other important gene sequences.

9. In Figure 3-20, what color is used to denote cytoplasm containing wild-type mitochondria?

Answer: Green is used to denote cytoplasm containing wild-type mitochondria?

10. In Figure 3-21, what would be the leaf types of progeny of the apical (top) flower?

Answer: The apical flower has variegated leaves and such gametes could be either with both chloroplast (therefore producing variegated offspring) or with only white or green, if chloroplasts segregate in the mature egg cell.

11. From the pedigree in Figure 3-25, what principle can you deduce about the inheritance of mitochondrial disease from affected fathers?

Answer: Human mitochondrial DNA is only inherited from the mothers.

BASIC PROBLEMS

12. Assume independent assortment and start with a plant that is dihybrid $A/a ; B/b$.
- What phenotypic ratio is produced from selfing it?
 - What genotypic ratio is produced from selfing it?
 - What phenotypic ratio is produced from testcrossing it?
 - What genotypic ratio is produced from testcrossing it?

Answer:

- a. The expected phenotypic ratio from the self cross of $A/a ; B/b$ is

9	$A/- ; B/-$
3	$A/- ; b/b$
3	$a/a ; B/-$
1	$a/a ; b/b$

- b. The expected genotypic ratio from the self cross of $A/a ; B/b$ is

1	$A/A ; B/B$
2	$A/A ; B/b$
1	$A/A ; b/b$
2	$A/a ; B/B$
4	$A/a ; B/b$
2	$A/a ; b/b$
1	$a/a ; B/B$
2	$a/a ; B/b$
1	$a/a ; b/b$

c. and d. The expected phenotypic and genotypic ratios from the testcross of $A/a ; B/b$ is

1	$A/a ; B/b$
1	$A/a ; b/b$
1	$a/a ; B/b$
1	$a/a ; b/b$

- 13.** Normal mitosis takes place in a diploid cell of genotype $A/a ; B/b$. Which of the following genotypes might represent possible daughter cells?
- $A ; B$
 - $a ; b$
 - $A ; b$
 - $a ; B$
 - $A/A ; B/B$
 - $A/a ; B/b$
 - $a/a ; b/b$

Answer: The resulting cells will have the identical genotype as the original cell: $A/a ; B/b$.

- 14.** In a diploid organism of $2n = 10$, assume that you can label all the centromeres derived from its female parent and all the centromeres derived from its male parent. When this organism produces gametes, how many male- and female-labeled centromere combinations are possible in the gametes?

Answer: The general formula for the number of different male/female centromeric combinations possible is 2^n , where n = number of different chromosome pairs. In this case, $2^5 = 32$.

- 15.** It has been shown that when a thin beam of light is aimed at a nucleus, the amount of light absorbed is proportional to the cell's DNA content. Using this method, the DNA in the nuclei of several different types of cells in a corn plant were compared. The following numbers represent the relative amounts of DNA in these different types of cells:

0.7, 1.4, 2.1, 2.8, and 4.2

Which cells could have been used for these measurements? (**Note:** In plants, the endosperm part of the seed is often triploid, $3n$.)

Answer: Because the DNA levels vary six-fold, the range covers cells that are haploid (spores or cells of the gametophyte stage) to cells that are triploid (the

endosperm) and dividing (after DNA has replicated but prior to cell division). The following cells would fit the DNA measurements:

- 0.7 haploid cells
- 1.4 diploid cells in G1 or haploid cells after S but prior to cell division
- 2.1 triploid cells of the endosperm
- 2.8 diploid cells after S but prior to cell division
- 4.2 triploid cells after S but prior to cell division

16. Draw a haploid mitosis of the genotype $a^+ ; b$.

Answer:

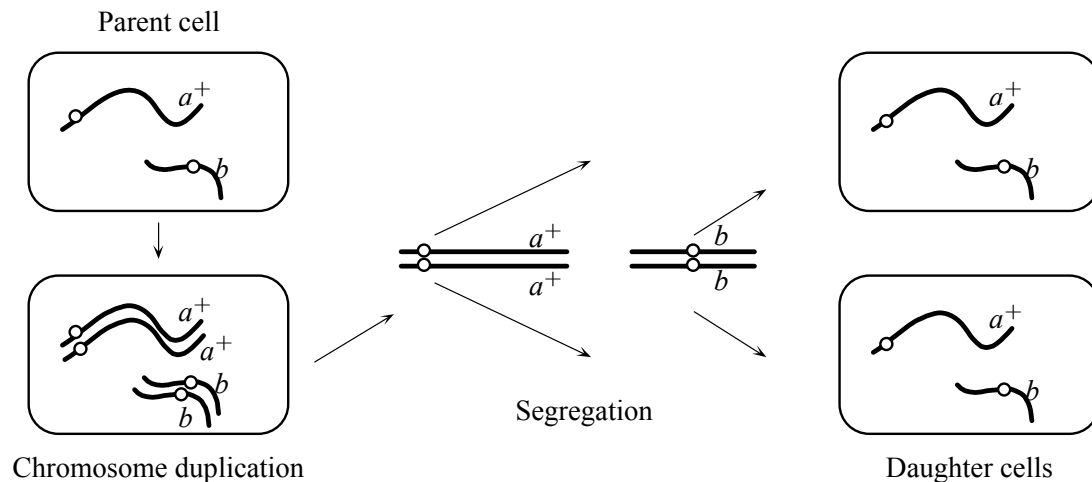

17. In moss, the genes A and B are expressed only in the gametophyte. A sporophyte of genotype $A/a ; B/b$ is allowed to produce gametophytes.
- a. What proportion of the gametophytes will be $A ; B$?
 - b. If fertilization is random, what proportion of sporophytes in the next generation will be $A/a ; B/b$?

Answer:

- a. A sporophyte of $A/a ; B/b$ genotype will produce gametophytes in the following proportions:
 - $1/4 A ; B$
 - $1/4 A ; b$
 - $1/4 a ; B$
 - $1/4 a ; b$
- b. Random fertilization of the spores from the above gametophytes can occur $4 \times 4 = 16$ possible ways. Four of these combinations ($A ; B' a ; b, a ; b' A ; B, A ; b' a ; B, a ; B' A ; b$) will result in the desired $A/a ; B/b$ sporophyte genotype. Therefore, $1/4$ of the next generation should be of this genotype.

18. When a cell of genotype $A/a ; B/b ; C/c$ having all the genes on separate chromosome pairs divides mitotically, what are the genotypes of the daughter cells?

Answer: Mitosis produces cells with the same starting genotype: $A/a ; B/b ; C/c$.

19. In the haploid yeast *Saccharomyces cerevisiae*, the two mating types are known as MAT α and MAT a . You cross a purple (ad^-) strain of mating type a and a white (ad^+) strain of mating type $\alpha\alpha$. If ad^- and ad^+ are alleles of one gene, and a and α are alleles of an independently inherited gene on a separate chromosome pair, what progeny do you expect to obtain? In what proportions?

Answer:

P	$ad^- ; a' ad^+ ; a$
Transient diploid	$ad^+/ad^- ; a/a$
F ₁	1/4 $ad^+ ; a$, white
	1/4 $ad^- ; a$, purple
	1/4 $ad^+ ; a$, white
	1/4 $ad^- ; a$, purple

20. In mice, dwarfism is caused by an X-linked recessive allele, and pink coat is caused by an autosomal dominant allele (coats are normally brownish). If a dwarf female from a pure line is crossed with a pink male from a pure line, what will be the phenotypic ratios in the F₁ and F₂ in each sex? (Invent and define your own gene symbols.)

Answer: The cross is female $X^d/X^d ; p/p'$ male $X^D/Y ; P/P$ where P = dominant allele for pink and d = recessive allele for dwarf.

F ₁	1/2 $X^D/X^d ; P/p$ (pink female)
	1/2 $X^d/Y ; P/p$ (dwarf, pink male)
F ₂	1/16 $X^D/X^d ; P/P$ (pink female)
	1/8 $X^D/X^d ; P/p$ (pink female)
	1/16 $X^D/X^d ; p/p$ (wild type female)
	1/16 $X^d/X^d ; P/P$ (dwarf, pink female)
	1/8 $X^d/X^d ; P/p$ (dwarf, pink female)
	1/16 $X^d/X^d ; p/p$ (dwarf female)
	1/16 $X^D/Y ; P/P$ (pink male)
	1/8 $X^D/Y ; P/p$ (pink male)
	1/16 $X^D/Y ; p/p$ (wild type male)
	1/16 $X^d/Y ; P/P$ (dwarf, pink male)
	1/8 $X^d/Y ; P/p$ (dwarf, pink male)
	1/16 $X^d/Y ; p/p$ (dwarf male)

21. Suppose you discover two interesting *rare* cytological abnormalities in the karyotype of a human male. (A karyotype is the total visible chromosome complement.) There is an extra piece (satellite) on *one* of the chromosomes of pair 4, and there is an abnormal pattern of staining on one of the chromosomes of pair 7. With the assumption that all the gametes of this male are equally viable, what proportion of his children will have the same karyotype that he has?

Answer: His children will have to inherit the satellite-containing 4 (probability = $1/2$), the abnormally-staining 7 (probability = $1/2$), and the Y chromosome (probability = $1/2$). To get all three, the probability is $(1/2)(1/2)(1/2) = 1/8$.

22. Suppose that meiosis occurs in the transient diploid stage of the cycle of a haploid organism of chromosome number n . What is the probability that an individual haploid cell resulting from the meiotic division will have a complete parental set of centromeres (that is, a set all from one parent or all from the other parent)?

Answer: The parental set of centromeres can match either parent, which means there are two ways to satisfy the problem. For any one pair, the probability of a centromere from one parent going into a specific gamete is $1/2$. For n pairs, the probability of all the centromeres being from one parent is $(1/2)^n$. Therefore, the total probability of having a haploid complement of centromeres from either parent is $2(1/2)^n = (1/2)^{n-1}$.

23. Pretend that the year is 1868. You are a skilled young lens maker working in Vienna. With your superior new lenses, you have just built a microscope that has better resolution than any others available. In your testing of this microscope, you have been observing the cells in the testes of grasshoppers and have been fascinated by the behavior of strange elongated structures that you have seen within the dividing cells. One day, in the library, you read a recent journal paper by G. Mendel on hypothetical “factors” that he claims explain the results of certain crosses in peas. In a flash of revelation, you are struck by the parallels between your grasshopper studies and Mendel’s pea studies, and you resolve to write him a letter. What do you write? (Based on an idea by Ernest Kroecker.)

Answer:

Dear Monk Mendel:

I have worked with grasshoppers, however, not your garden peas. Although you are a man of the cloth, you are also a man of science, and I pray that you will not be offended when I state that I have specifically studied the reproductive organs of male grasshoppers. Indeed, I did not limit myself to studying the

organs themselves; instead, I also studied the smaller units that make up the male organs and have beheld structures most amazing within them.

These structures are contained within numerous small bags within the male organs. Each bag has a number of these structures, which are long and threadlike at some times and short and compact at other times. They come together in the middle of a bag, and then they appear to divide equally. Shortly thereafter, the bag itself divides, and what looks like half of the threadlike structures goes into each new bag. Could it be, Sir, that these threadlike structures are the very same as your factors? I know, of course, that garden peas do not have male organs in the same way that grasshoppers do, but it seems to me that you found it necessary to emasculate the garden peas in order to do some crosses, so I do not think it too far-fetched to postulate a similarity between grasshoppers and garden peas in this respect.

Pray, Sir, do not laugh at me and dismiss my thoughts on this subject even though I have neither your excellent training nor your astounding wisdom in the Sciences. I remain your humble servant to eternity!

24. From a presumed testcross $A/a \times a/a$, in which A represents red and a represents white, use the χ^2 test to find out which of the following possible results would fit the expectations:
- 120 red, 100 white
 - 5000 red, 5400 white
 - 500 red, 540 white
 - 50 red, 54 white

Answer: The hypothesis is that the organism being tested is a heterozygote and that the A/a and a/a progeny are of equal viability. The expected values would be that phenotypes occur with equal frequency. There are two genotypes in each case, so there is one degree of freedom.

$$c^2 = \sum (\text{observed}-\text{expected})^2/\text{expected}$$

- $c^2 = [(120-110)^2 + (100-110)^2]/110$
 $= 1.818; p > 0.10$, nonsignificant; hypothesis cannot be rejected
- $c^2 = [(5000-5200)^2 + (5400-5200)^2]/5200$
 $= 15.385; p < 0.005$, significant; hypothesis must be rejected
- $c^2 = [(500-520)^2 + (540-520)^2]/520$
 $= 1.538; p > 0.10$, nonsignificant; hypothesis cannot be rejected
- $c^2 = [(50-52)^2 + (54-52)^2]/52$
 $= 0.154; p > 0.50$, nonsignificant; hypothesis cannot be rejected

25. Look at the Punnett square in Figure 3-4.
- How many genotypes are there in the 16 squares of the grid?
 - What is the genotypic ratio underlying the 9 : 3 : 3 : 1 phenotypic ratio?
 - Can you devise a simple formula for the calculation of the number of progeny genotypes in dihybrid, trihybrid, and so forth crosses? Repeat for phenotypes.
 - Mendel predicted that, within all but one of the phenotypic classes in the Punnett square, there should be several different genotypes. In particular, he performed many crosses to identify the underlying genotypes of the round, yellow phenotype. Show two different ways that could be used to identify the various genotypes underlying the round, yellow phenotype. (Remember, all the round, yellow peas look identical.)

Answer:

- This is simply a matter of counting genotypes; there are nine genotypes in the Punnett square. Alternatively, you know there are three genotypes possible per gene, for example R/R , R/r , and r/r , and since both genes assort independently, there are $3 \times 3 = 9$ total genotypes.
- Again, simply count. The genotypes are

$1 R/R ; Y/Y$	$1 r/r ; Y/Y$	$1 R/R ; y/y$	$1 r/r ; y/y$
$2 R/r ; Y/Y$	$2 r/r ; Y/y$	$2 R/r ; y/y$	
$2 R/R ; Y/y$			
$4 R/r ; Y/y$			
- To find a formula for the number of genotypes, first consider the following:

Number of genes	Number of genotypes	Number of phenotypes
1	$3 = 3^1$	$2 = 2^1$
2	$9 = 3^2$	$4 = 2^2$
3	$27 = 3^3$	$8 = 2^3$

Note that the number of genotypes is 3 raised to some power in each case. In other words, a general formula for the number of genotypes is 3^n , where n equals the number of genes.

For allelic relationships that show complete dominance, the number of phenotypes is 2 raised to some power. The general formula for the number of phenotypes observed is 2^n , where n equals the number of genes.

- The round, yellow phenotype is $R/- ; Y/-$. Two ways to determine the exact genotype of a specific plant are through selfing or conducting a testcross.

With selfing, complete heterozygosity will yield a 9:3:3:1 phenotypic ratio. Homozygosity at one locus will yield a 3:1 phenotypic ratio, while homozygosity at both loci will yield only one phenotypic class.

With a testcross, complete heterozygosity will yield a 1:1:1:1 phenotypic ratio. Homozygosity at one locus will yield a 1:1 phenotypic ratio, while homozygosity at both loci will yield only one phenotypic class.

26. Assuming independent assortment of all genes, develop formulas that show the number of phenotypic classes and the number of genotypic classes from selfing a plant heterozygous for n gene pairs.

Answer: Assuming independent assortment and simple dominant/recessive relationships of all genes, the number of genotypic classes expected from selfing a plant heterozygous for n gene pairs is 3^n and the number of phenotypic classes expected is 2^n .

27. **Note:** The first part of this problem was introduced in Chapter 2. The line of logic is extended here.

In the plant *Arabidopsis thaliana*, a geneticist is interested in the development of trichomes (small projections) on the leaves. A large screen turns up two mutant plants (A and B) that have no trichomes, and these mutants seem to be potentially useful in studying trichome development. (If they are determined by single-gene mutations, then finding the normal and abnormal function of these genes will be instructive.) Each plant was crossed with wild type; in both cases, the next generation (F_1) had normal trichomes. When F_1 plants were selfed, the resulting F_2 's were as follows:

F_2 from mutant A: 602 normal ; 198 no trichomes

F_2 from mutant B: 267 normal ; 93 no trichomes

- What do these results show? Include proposed genotypes of all plants in your answer.
- Assume that the genes are located on separate chromosomes. An F_1 is produced by crossing the original mutant A with the original mutant B. This F_1 is testcrossed: What proportion of testcross progeny will have no trichomes?

Answer:

- The data for both crosses suggest that both A and B mutant plants are homozygous for a recessive allele. Both F_2 crosses give 3:1 normal to mutant ratios of progeny. For example, let A = normal and a = mutant, then

P A/A' a/a

F₁ A/a
 F₂ 1 A/A phenotype: normal
 2 A/a phenotype: normal
 1 a/a phenotype: mutant (no trichomes)

- b. The cross is $A/A ; b/b' a/a ; B/B$ to give the F₁ of $A/a ; B/b$. This is then test crossed (crossed to $a/a ; b/b$) to give

1/4 $A/a ; B/b$ (normal)
 1/4 $A/a ; b/b$ (no trichomes)
 1/4 $a/a ; B/b$ (no trichomes)
 1/4 $a/a ; b/b$ (no trichomes)
 or 1 normal : 3 no trichomes

28. In dogs, dark coat color is dominant over albino and short hair is dominant over long hair. Assume that these effects are caused by two independently assorting genes, and write the genotypes of the parents in each of the crosses shown here, in which D and A stand for the dark and albino phenotypes, respectively, and S and L stand for the short-hair and long-hair phenotypes.

Parental phenotypes	Number of progeny			
	D, S	D, L	A, S	A, L
a. D, S × D, S	89	31	29	11
b. D, S × D, L	18	19	0	0
c. D, S × A, S	20	0	21	0
d. A, S × A, S	0	0	28	9
e. D, L × D, L	0	32	0	10
f. D, S × D, S	46	16	0	0
g. D, S × D, L	30	31	9	11

Use the symbols C and c for the dark and albino coat-color alleles and the symbols S and s for the short-hair and long-hair alleles, respectively. Assume homozygosity unless there is evidence otherwise. (Problem 28 is reprinted by permission of Macmillan Publishing Co., Inc., from M. Strickberger, *Genetics*. Copyright 1968 by Monroe W. Strickberger.)

Answer:

- a. $C/c ; S/s'$ $C/c ; S/s$ There are 3 short : 1 long, and 3 dark : 1 albino. Therefore, each gene is heterozygous in the parents.
- b. $C/C ; S/s'$ $C/- ; s/s$ There are no albino, and there are 1 long : 1 short indicating a testcross for this trait.
- c. $C/c ; S/S'$ $c/c ; S/-$ There are no long, and there are 1 dark : 1 albino.
- d. $c/c ; S/s'$ $c/c ; S/s$ All are albino, and there are 3 short : 1 long.
- e. $C/c ; s/s'$ $C/c ; s/s$ All are long, and there are 3 dark : 1 albino.

- f. $C/C ; S/s' \quad C/- ; S/s$ There are no albino, and there are 3 short : 1 long.
 g. $C/c ; S/s' \quad C/c ; s/s$ There are 3 dark : 1 albino and 1 short : 1 long.

29. In tomatoes, two alleles of one gene determine the character difference of purple (P) versus green (G) stems, and two alleles of a separate, independent gene determine the character difference of “cut” (C) versus “potato” (Po) leaves. The results for five matings of tomato-plant phenotypes are as follows:

Mating	Parental phenotypes	Number of progeny			
		P, C	P, Po	G, C	G, Po
1	P, C × G, C	321	101	310	107
2	P, C × P, Po	219	207	64	71
3	P, C × G, C	722	231	0	0
4	P, C × G, Po	404	0	87	0
5	P, Po × G, C	70	91	86	77

- a. Determine which alleles are dominant.
 b. What are the most probable genotypes for the parents in each cross? (Problem 29 is from A. M. Srb, R. D. Owen, and R. S. Edgar, *General Genetics*, 2nd ed. Copyright 1965 by W. H. Freeman and Company.)

Answer:

- a. Cross 2 indicates that purple (G) is dominant to green (g), and cross 1 indicates cut (P) is dominant to potato (p).
 b.
 Cross 1: $G/g ; P/p' \quad g/g ; P/p$ There are 3 cut : 1 potato, and 1 purple : 1 green.
 Cross 2: $G/g ; P/p' \quad G/g ; p/p$ There are 3 purple : 1 green and 1 cut : 1 potato.
 Cross 3: $G/G ; P/p' \quad g/g ; P/p$ There are no green, and there are 3 cut : 1 potato.
 Cross 4: $G/g ; P/P' \quad g/g ; p/p$ There are no potatoes, and there are 1 purple : 1 green.
 Cross 5: $G/g ; p/p' \quad g/g ; P/p$ There are 1 cut : 1 potato, and there are 1 purple : 1 green.

30. A mutant allele in mice causes a bent tail. Six pairs of mice were crossed. Their phenotypes and those of their progeny are given in the following table. N is normal phenotype; B is bent phenotype. Deduce the mode of inheritance of this phenotype.

Cross	Parents		Progeny	
	♀	♂	♀	♂
1	N	B	All B	All N

2	B	N	1/2B, 1/2N	1/2B, 1/2N
3	B	N	All B	All B
4	N	N	All N	All N
5	B	B	All B	All B
6	B	B	All B	1/2B, 1/2N

- Is it recessive or dominant?
- Is it autosomal or sex-linked?
- What are the genotypes of all parents and progeny?

Answer:

- From cross 6, bent (B) is dominant to normal (b). Both parents are “bent,” yet some progeny are “normal.”
- From cross 1, it appears that the trait is inherited in a sex-specific manner, in this case as X-linked (since sons always inherit one of the mother’s X chromosomes).
- In the following table, the Y chromosome is stated; the X is implied.

Cross	Parents		Progeny	
	♀	♂	♀	♂
1	b/b	B/Y	B/b	b/Y
2	B/b	b/Y	$B/b, b/b$	$B/Y, b/Y$
3	B/B	b/Y	B/b	B/Y
4	b/b	b/Y	b/b	b/Y
5	B/B	B/Y	$/B$	B/Y
6	B/b	B/Y	$B/B, B/b$	$B/Y, b/Y$

31. The normal eye color of *Drosophila* is red, but strains in which all flies have brown eyes are available. Similarly, wings are normally long, but there are strains with short wings. A female from a pure line with brown eyes and short wings is crossed with a male from a normal pure line. The F_1 consists of normal females and short-winged males. An F_2 is then produced by intercrossing the F_1 . Both sexes of F_2 flies show phenotypes as follows:

3/8 red eyes, long wings
 3/8 red eyes, short wings
 1/8 brown eyes, long wings
 1/8 brown eyes, short wings

Deduce the inheritance of these phenotypes; use clearly defined genetic symbols of your own invention. State the genotypes of all three generations and the genotypic proportions of the F_1 and F_2 .

Unpacking Problem 31

Before attempting a solution to this problem, try answering the following questions:

1. What does the word “normal” mean in this problem?

Answer: *Normal* is used to mean wild type, or red eye color and long wings.

2. The words “line” and “strain” are used in this problem. What do they mean, and are they interchangeable?

Answer: Both *line* and *strain* are used to denote pure-breeding fly stocks, and the words are interchangeable.

3. Draw a simple sketch of the two parental flies showing their eyes, wings, and sexual differences.

Answer: Your choice.

4. How many different characters are there in this problem?

Answer: Three characters are being followed: eye color, wing length, and sex.

5. How many phenotypes are there in this problem, and which phenotypes go with which characters?

Answer: For eye color, there are two phenotypes: red and brown. For wing length, there are two phenotypes: long and short. For sex, there are two phenotypes: male and female.

6. What is the full phenotype of the F₁ females called “normal”?

Answer: The F₁ females designated normal have red eyes and long wings.

7. What is the full phenotype of the F₁ males called “short winged”?

Answer: The F₁ males that are called short-winged have red eyes and short wings.

8. List the F_2 phenotypic ratios for each character that you came up with in answer to question 4.

Answer: The F_2 ratio is:
3/8 red eyes, long wings
3/8 red eyes, short wings
1/8 brown eyes, long wings
1/8 brown eyes, short wings

9. What do the F_2 phenotypic ratios tell you?

Answer: Because there is not the expected 9:3:3:1 ratio, one of the factors that distorts the expected dihybrid ratio must be present. Such factors can be sex linkage, epistasis, genes on the same chromosome, environmental effect, reduced penetrance, or a lack of complete dominance in one or both genes.

10. What major inheritance pattern distinguishes sex-linked inheritance from autosomal inheritance?

Answer: With sex linkage, traits are inherited in a sex-specific way. With autosomal inheritance, males and females have the same probabilities of inheriting the trait.

11. Do the F_2 data show such a distinguishing criterion?

Answer: The F_2 does not indicate sex-specific inheritance.

12. Do the F_1 data show such a distinguishing criterion?

Answer: The F_1 data does show sex-specific inheritance—all males are short-winged, like their mothers, while all females are normal-winged, like their fathers.

13. What can you learn about dominance in the F_1 ? The F_2 ?

Answer: The F_1 suggests that long is dominant to short and red is dominant to brown. The F_2 data show a 3 red : 1 brown ratio indicating the dominance of red but a 1 : 1 long : short ratio indicative of a testcross. Without the F_1 data, it is not possible to determine which form of the wing character is dominant.

14. What rules about wild-type symbolism can you use in deciding which allelic symbols to invent for these crosses?

Answer: If Mendelian notation is used, then the red and long alleles need to be designated with uppercase letters, for example R and L , while the brown (r) and short (l) alleles need to be designated with lowercase letters. If *Drosophila* notation is used, then the brown allele may be designated with a lowercase b and the wild-type (red) allele with a b^+ ; the short wing-length gene with an s and the wild-type (long) allele with an s^+ . (Genes are often named after their mutant phenotype.)

15. What does “deduce the inheritance of these phenotypes” mean?

Answer: To deduce the inheritance of these phenotypes means to provide all genotypes for all animals in the three generations discussed and account for the ratios observed.

Now try to solve the problem. If you are unable to do so, make a list of questions about the things that you do not understand. Inspect the key concepts at the beginning of the chapter and ask yourself which are relevant to your questions. If this approach doesn't work, inspect the messages of this chapter and ask yourself which might be relevant to your questions.

Solution to the Problem

Start this problem by writing the crosses and results so that all the details are clear.

P brown, short female' red, long male
 F₁ red, long females
 red, short males

These results tell you that red-eyed is dominant to brown-eyed, and since both females and males are red-eyed, this gene is autosomal. Since males differ from females in their genotype with regard to wing length, this trait is sex-linked. Knowing that *Drosophila* females are XX and males are XY, the long-winged females tell us that long is dominant to short and that the gene is X-linked. Let B = red, b = brown, S = long, and s = short. The cross can be rewritten as follows:

P $b/b ; s/s' B/B ; S/Y$

F₁ $1/2 B/b ; S/s$ females
 $1/2 B/b ; s/Y$ males

F₂ $1/16 B/B ; S/s$ red, long, female
 $1/16 B/B ; s/s$ red, short, female
 $1/8 B/b ; S/s$ red, long, female

$1/8 B/b ; s/s$	red, short, female
$1/16 b/b ; S/s$	brown, long, female
$1/16 b/b ; s/s$	brown, short, female
$1/16 B/B ; S/Y$	red, long, male
$1/16 B/B ; s/Y$	red, short, male
$1/8 B/b ; S/Y$	red, long, male
$1/8 B/b ; s/Y$	red, short, male
$1/16 b/b ; S/Y$	brown, long, male
$1/16 b/b ; s/Y$	brown, short, male

The final phenotypic ratio is

$3/8$ red, long

$3/8$ red, short

$1/8$ brown, long

$1/8$ brown, short

with equal numbers of males and females in all classes.

- 32.** In a natural population of annual plants, a single plant is found that is sickly looking and has yellowish leaves. The plant is dug up and brought back to the laboratory. Photosynthesis rates are found to be very low. Pollen from a normal dark-green-leaved plant is used to fertilize emasculated flowers of the yellowish plant. A hundred seeds result, of which only 60 germinate. All the resulting plants are sickly yellow in appearance.
- Propose a genetic explanation for the inheritance pattern.
 - Suggest a simple test for your model.
 - Account for the reduced photosynthesis, sickliness, and yellowish appearance.

Answer:

- Because photosynthesis is affected and the plants are yellow rather than green, it is likely that the chloroplasts are defective. If the defect maps to the DNA of the chloroplast, the trait will be maternally inherited. This fits the data that all progeny have the phenotype of the female parent and not the phenotype of the male (pollen-donor) parent.
- If the defect maps to the DNA of the chloroplast, the trait will be maternally inherited. Use pollen from sickly, yellow plants and cross to emasculated flowers of a normal dark green-leaved plant. All progeny should have the normal dark green phenotype.
- The chloroplasts contain the green pigment chlorophyll and are the site of photosynthesis. A defect in the production of chlorophyll would give rise to all the stated defects.

33. What is the basis for the green-and-white color variegation in the leaves of *Mirabilis*? If the following cross is made,

variegated ♀ × green ♂

what progeny types can be predicted? What about the reciprocal cross?

Answer: Maternal inheritance of chloroplasts results in the green-white color variegation observed in *Mirabilis*.

Cross 1: variegated female ♀ green male ♂ variegated, green, or white progeny
 Cross 2: green female ♀ variegated male ♂ green progeny

In both crosses, the pollen (male contribution) contains no chloroplasts and thus does not contribute to the inheritance of this phenotype. Eggs from a variegated female plant can be of three types : contain only “green” chloroplasts, contain only “white” chloroplasts, or contain both (variegated). The offspring will have the phenotype associated with the egg’s chloroplasts.

34. In *Neurospora*, the mutant *stp* exhibits erratic stop-and-start growth. The mutant site is known to be in the mtDNA. If an *stp* strain is used as the female parent in a cross with a normal strain acting as the male, what type of progeny can be expected? What about the progeny from the reciprocal cross?

Answer: The crosses are

Cross 1: stop-start female ♀ wild-type male ♂ all stop-start progeny

Cross 2: wild-type female ♀ stop-start male ♂ all wild-type progeny mtDNA is inherited only from the “female” in *Neurospora*

35. Two corn plants are studied. One is resistant (R) and the other is susceptible (S) to a certain pathogenic fungus. The following crosses are made, with the results shown:

S ♀ × R ♂ → all progeny S

R ♀ × S ♂ → all progeny R

What can you conclude about the location of the genetic determinants of R and S?

Answer: The genetic determinants of R and S are showing maternal inheritance and are therefore cytoplasmic. It is possible that the gene that confers resistance maps either to the mtDNA or cpDNA.

36. A presumed dihybrid in *Drosophila*, $B/b ; F/f$ is testcrossed with $b/b ; f/f$. ($B =$

black body ; b = brown body; F = forked bristles; f = unforked bristles.) The results are

Black, forked	230
Black, unforked	210
Brown, forked	240
Brown, unforked	250

Use the χ^2 test to determine if these results fit the results expected from testcrossing the hypothesized dihybrid.

Answer: The hypothesis is that the organism being tested is a dihybrid with independently assorting genes and that all progeny are of equal viability. The expected values would be that phenotypes occur with equal frequency. There are four phenotypes so there are 3 degrees of freedom.

$$c^2 = \sum (\text{observed-expected})^2/\text{expected}$$

$$c^2 = [(230-233)^2 + (210-233)^2 + (240-233)^2 + (250-233)^2]/233$$

= 3.75; p value between 0.1 and 0.5, nonsignificant; hypothesis cannot be rejected

37. Are the following progeny numbers consistent with the results expected from selfing a plant presumed to be a dihybrid of two independently assorting genes, H/h ; R/r ? (H = hairy leaves; h = smooth leaves; R = round ovary; r = elongated ovary.) Explain your answer.

hairy, round	178
hairy, elongated	62
smooth, round	56
smooth, elongated	24

Answer: The hypothesis is that the organism being tested is a dihybrid with independently assorting genes and that all progeny are of equal viability. The expected values would be that phenotypes occur in a 9 : 3 : 3 : 1 ratio. There are four phenotypes so there are 3 degrees of freedom.

$$c^2 = \sum (\text{observed-expected})^2/\text{expected}$$

$$c^2 = (178-180)^2/180 + (62-60)^2/60 + (56-60)^2/60 + (24-20)^2/20$$

= 1.156; $p > 0.50$, nonsignificant; hypothesis cannot be rejected

38. A dark female moth is crossed with a dark male. All the male progeny are dark, but half the female progeny are light and the rest are dark. Propose an explanation for this pattern of inheritance.

Answer: When results of a cross are sex-specific, sex linkage should be considered. In moths, the heterogametic sex is actually the female while the male is the homogametic sex. Assuming that dark (D) is dominant to light (d), then the data can be explained by the dark male being heterozygous (D/d) and the dark female being hemizygous (D). All male progeny will inherit the D allele from their mother and therefore be dark, while half the females will inherit D from their father, (and be dark) and half will inherit d (and be light).

39. In *Neurospora*, a mutant strain called stopper (stp) arose spontaneously. Stopper showed erratic “stop and start” growth, compared with the uninterrupted growth of wild-type strains. In crosses, the following results were found:

♀ stopper × ♂ wild type → progeny all stopper
 ♀ wild type × ♂ stopper → progeny all wild type

- a. What do these results suggest regarding the location of the stopper mutation in the genome?
 b. According to your model for part a, what progeny and proportions are predicted in octads from the following cross, including a mutation nic^3 located on chromosome VI?

♀ $stp \cdot nic^3$ × wild type ♂

Answer:

- a. This inheritance pattern is diagnostic for cytoplasmic organelle inheritance. These crosses indicate the mutant gene resides in the mitochondria. (*Neurospora* is a fungi and does not have chloroplasts.)
 b. All progeny from this cross will have the “maternal” trait stopper but the nic^3 allele should segregate 1:1 in the octad—four spores will be $stp ; nic^3$ and four spores will be $stp ; nic^3^+$.
40. In polygenic systems, how many phenotypic classes corresponding to number of polygene “doses” are expected in selfs
- a. of strains with four heterozygous polygenes?
 b. of strains with six heterozygous polygenes?

Answer:

- a. There should be nine classes—0, 1, 2, 3, 4, 5, 6, 7, 8 “doses.”
 b. There should be 13 classes—0, 1, 2, 3, 4, 5, 6, 7, 8, 9, 10, 11, 12 “doses.”
41. In the self of a polygenic trihybrid $R_1/r_1 ; R_2/r_2 ; R_3/r_3$, use the product and sum rules to calculate the proportion of progeny with just one polygene “dose.”

Answer: There are three ways for a self cross of this genotype to give rise to just one dose — one dose of R_1 and none of R_2 or R_3 ; one dose of R_2 and none of R_1 or R_3 ; or one dose of R_3 and none of R_1 or R_2 . The chance of inheriting one dose of R_1 (from $R_1/r_1 \times R_1/r_1$) is $1/2$. The chance of no doses of R_2 (from $R_2/r_2 \times R_2/r_2$) is $1/4$ as is the chance of no doses of R_3 (from $R_3/r_3 \times R_3/r_3$). Therefore, the desired outcome of just one dose is $3 \times 1/2 \times 1/4 \times 1/4 = 3/32$.

42. Reciprocal crosses and selfs were performed between the two moss species *Funaria mediterranea* and *F. hygrometrica*. The sporophytes and the leaves of the gametophytes are shown in the accompanying diagram.

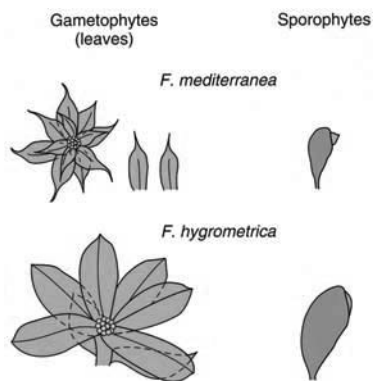

The crosses are written with the female parent first.

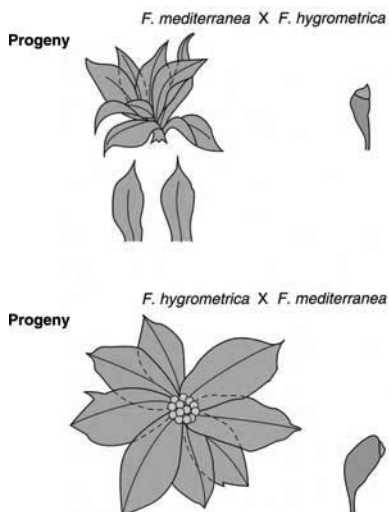

- Describe the results presented, summarizing the main findings.
- Propose an explanation of the results.
- Show how you would test your explanation; be sure to show how it could be distinguished from other explanations.

Answer:

- a. Both the gametophyte and the sporophyte are closer in shape to the mother than the father. Note that a size increase occurs in each type of cross.
 - b. Gametophyte and sporophyte morphology might be affected by cytoplasmic inheritance (from eggs) or similar extranuclear factors. Leaf size may be a function of the interplay between nuclear genome contributions.
 - c. If extranuclear factors are affecting morphology while nuclear factors are affecting leaf size, then repeated backcrosses could be conducted, using the hybrid as the female. This would result in the cytoplasmic information remaining constant while the nuclear information becomes increasingly like that of the backcross parent. Leaf morphology should therefore remain constant while leaf size would decrease toward the size of the backcross parent.
- 43.** Assume that diploid plant A has a cytoplasm genetically different from that of plant B. To study nuclear–cytoplasmic relations, you wish to obtain a plant with the cytoplasm of plant A and the nuclear genome predominantly of plant B. How would you go about producing such a plant?

Answer: The goal here is to generate a plant with the cytoplasm of plant A and the nuclear genome predominantly of plant B. Remember that the cytoplasm is contributed by the egg only. So using plant A as the maternal parent, cross to B (as the paternal parent) and then backcross the progeny of this cross using plant B again as the paternal parent. Repeat for several generations until virtually the entire nuclear genome is from the B parent.

- 44.** You are studying a plant with tissue comprising both green and white sectors. You wish to decide whether this phenomenon is due (1) to a chloroplast mutation of the type considered in this chapter or (2) to a dominant nuclear mutation that inhibits chlorophyll production and is present only in certain tissue layers of the plant as a mosaic. Outline the experimental approach that you would use to resolve this problem.

Answer: If the variegation is due to a chloroplast mutation, then the phenotype of the offspring will be controlled solely by the phenotype of the maternal parent. Look for flowers on white branches and test to see if they produce seeds that grow into all white plants regardless of the source of the pollen. To test whether a dominant nuclear mutation is responsible for the variegation, cross pollen from flowers on white branches to green plants (or flowers on green branches of same plant) and see if half the progeny are white and half are green (assuming the dominant mutation is heterozygous) or all white, if the dominant mutation is homozygous.

45. Early in the development of a plant, a mutation in cpDNA removes a specific BgIII restriction site (B) as follows:

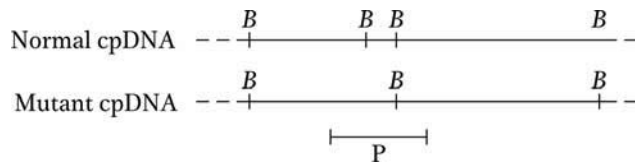

In this species, cpDNA is inherited maternally. Seeds from the plant are grown, and the resulting progeny plants are sampled for cpDNA. The cpDNAs are cut with BgIII, and Southern blots are hybridized with the probe P shown. The autoradiograms show three patterns of hybridization:

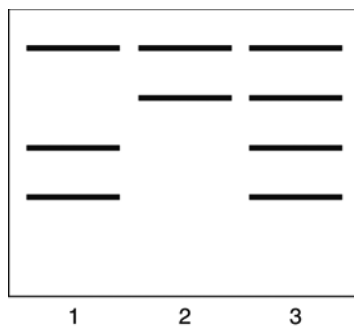

Explain the production of these three seed types.

Answer: Progeny plants inherited only normal chloroplast, cpDNA (lane 1); only mutant cpDNA (lane 2); or both (lane 3). In order to get homoplasmic cpDNA (all chloroplasts containing the same DNA), seen in lanes 1 and 2, segregation of chloroplasts had to occur.

CHALLENGING PROBLEMS

46. You have three jars containing marbles, as follows:

jar 1	600 red	and	400 white
jar 2	900 blue	and	100 white
jar 3	10 green	and	990 white

- a. If you blindly select one marble from each jar, calculate the probability of obtaining
- (1) a red, a blue, and a green.
 - (2) three whites.
 - (3) a red, a green, and a white.
 - (4) a red and two whites.
 - (5) a color and two whites.
 - (6) at least one white.

- b. In a certain plant, R = red and r = white. You self a red R/r heterozygote with the express purpose of obtaining a white plant for an experiment. What minimum number of seeds do you have to grow to be at least 95 percent certain of obtaining at least one white individual?
- c. When a woman is injected with an egg fertilized in vitro, the probability of its implanting successfully is 20 percent. If a woman is injected with five eggs simultaneously, what is the probability that she will become pregnant? (Part c is from Margaret Holm.)

Answer:

- a. Before beginning the specific problems, calculate the probabilities associated with each jar.

$$\text{jar 1 } p(R) = 600/(600 + 400) = 0.6$$

$$p(W) = 400/(600 + 400) = 0.4$$

$$\text{jar 2 } p(B) = 900/(900 + 100) = 0.9$$

$$p(W) = 100/(900 + 100) = 0.1$$

$$\text{jar 3 } p(G) = 10/(10 + 990) = 0.01$$

$$p(W) = 990/(10 + 990) = 0.99$$

$$(1) p(R, B, G) = (0.6)(0.9)(0.01) = 0.0054$$

$$(2) p(W, W, W) = (0.4)(0.1)(0.99) = 0.0396$$

- (3) Before plugging into the formula, you should realize that, while white can come from any jar, red and green must come from specific jars (jar 1 and jar 3). Therefore, white must come from jar 2:

$$p(R, W, G) = (0.6)(0.1)(0.01) = 0.0006$$

$$(4) p(R, W, W) = (0.6)(0.1)(0.99) = 0.0594$$

- (5) There are three ways to satisfy this:

$$R, W, W \text{ or } W, B, W \text{ or } W, W, G$$

$$= (0.6)(0.1)(0.99) + (0.4)(0.9)(0.99) + (0.4)(0.1)(0.01)$$

$$= 0.0594 + 0.3564 + 0.0004 = 0.4162$$

- (6) At least one white is the same as 1 minus no whites:

$$p(\text{at least 1 W}) = 1 - p(\text{no W}) = 1 - p(R, B, G)$$

$$= 1 - (0.6)(0.9)(0.01) = 1 - 0.0054 = 0.9946$$

- b. The cross is $R/r \times R/r$. The probability of red ($R/-$) is $3/4$, and the probability of white (r/r) is $1/4$. Because only one white is needed, the only unacceptable result is all red.

In n trials, the probability of all red is $(3/4)^n$. Because the probability of failure must be no greater than 5 percent:

$$(3/4)^n < 0.05$$

$$n > 10.41, \text{ or } 11 \text{ seeds}$$

- c. The $p(\text{failure}) = 0.8$ for each egg. Since all eggs are implanted simultaneously, the $p(5 \text{ failures}) = (0.8)^5$. The $p(\text{at least one success}) = 1 - (0.8)^5 = 1 - 0.328 = 0.672$

47. In tomatoes, red fruit is dominant over yellow, two-loculed fruit is dominant over many-loculed fruit, and tall vine is dominant over dwarf. A breeder has two pure lines: (1) red, two-loculed, dwarf and (2) yellow, many-loculed, tall. From these two lines, he wants to produce a new pure line for trade that is yellow, two-loculed, and tall. How exactly should he go about doing so? Show not only which crosses to make, but also how many progeny should be sampled in each case.
- a. One of the genes is obviously quite distant from the other three, which appear to be tightly (closely) linked. Which is the distant gene?
- b. What is the probable order of the three tightly linked genes?

(Problem 47 is from Franklin Stahl, *The Mechanics of Inheritance*, 2nd ed. Copyright 1969, Prentice Hall, Englewood Cliffs, N.J. Reprinted by permission.)

Answer: Use the following symbols:

Gene function	Dominant allele	Recessive allele
color	$R = \text{red}$	$r = \text{yellow}$
loculed	$L = \text{two}$	$l = \text{many}$
height	$H = \text{tall}$	$h = \text{dwarf}$

The starting plants are pure-breeding, so their genotypes are:

red, two-loculed, dwarf $R/R ; L/L ; h/h$
 and
 yellow, many-loculed, tall $r/r ; l/l ; H/H$

The farmer wants to produce a pure-breeding line that is yellow, two-loculed, and tall, which would have the genotype $r/r ; L/L ; H/H$.

The two pure-breeding starting lines will produce an F_1 that will be $R/r ; L/l ; H/h$. By doing an $F_1 \times F_1$ cross, $1/64$ of the F_2 progeny should have the correct genotype ($1/4 r/r \times 1/4 L/L \times 1/4 H/H$). The probability of NOT getting that is $(1 - 1/64)^n$, where n is number of progeny scored. For that to be less than 5 percent, n

= 191. So we need at least 191 progeny to start with, and by selecting yellow, two-loculed, and tall plants from these progeny, the known genotype will be r/r ; $L/-$; $H/-$. To identify how many of these are required for further testing (by test cross): the probability of being homozygous dominant for both (given that we are selecting only from those plants with dominant phenotypes) is $1/3 \times 1/3 = 1/9$. Therefore, the probability of a plant not being homozygous for both is $8/9$. We want the probability of all plants tested not being homozygous for both to be less than 5 percent, or $(8/9)^n < 0.05$. If $n = 26$, $p = .047$. So at least 26 of the yellow, two-loculed, and tall progeny should be testcrossed to a l/l ; h/h parent to determine which are homozygous for the two dominant traits. (**Note:** Several l/l ; h/h testers are likely to be recovered among the 191 F_2 progeny generated. So you will only need one testcross for each candidate.)

For each testcross, the plant will obviously be discarded if the testcross reveals a heterozygous state for the gene in question. If no recessive allele is detected, then the minimum number of progeny that must be examined to be 95 percent confident that the plant is homozygous is based on the frequency of the dominant phenotype if heterozygous, which is $1/2$. In n progeny, the probability of obtaining all dominant progeny in a testcross, given that the plant is heterozygous, is $(1/2)^n$. To be 95 percent confident of homozygosity, the following formula is used, where 5 percent is the probability that it is not homozygous:

$$(1/2)^n = 0.05$$

$n = 4.3$, or 5 phenotypically dominant progeny must be obtained from each testcross to be 95 percent confident that the plant is homozygous.

48. We have dealt mainly with only two genes, but the same principles hold for more than two genes. Consider the following cross:

$$A/a ; B/b ; C/c ; D/d ; E/e \times a/a ; B/b ; c/c ; D/d ; e/e$$

- a. What proportion of progeny will phenotypically resemble (1) the first parent, (2) the second parent, (3) either parent, and (4) neither parent?
- b. What proportion of progeny will be genotypically the same as (1) the first parent, (2) the second parent, (3) either parent, and (4) neither parent? Assume independent assortment.

Answer:

- a. Because each gene assort independently, each probability should be considered separately and then multiplied together for the answer.

For (1) $1/2$ will be A , $3/4$ will be B , $1/2$ will be C , $3/4$ will be D , and $1/2$ will be E .

$$1/2 \times 3/4 \times 1/2 \times 3/4 \times 1/2 = 9/128$$

For (2) $1/2$ will be a , $3/4$ will be B , $1/2$ will be c , $3/4$ will be D , and $1/2$ will be e .

$$1/2 \times 3/4 \times 1/2 \times 3/4 \times 1/2 = 9/128$$

For (3) it is the sum of (1) and (2) = $9/128 + 9/128 = 9/64$

For (4) it is $1 - (\text{part 3}) = 1 - 9/64 = 55/64$

- b.** For (1) $1/2$ will be A/a , $1/2$ will be B/b , $1/2$ will be C/c , $1/2$ will be D/d , and $1/2$ will be E/e .

$$1/2 \times 1/2 \times 1/2 \times 1/2 \times 1/2 = 1/32$$

For (2) $1/2$ will be a/a , $1/2$ will be B/b , $1/2$ will be c/c , $1/2$ will be D/d , and $1/2$ will be e/e .

$$1/2 \times 1/2 \times 1/2 \times 1/2 \times 1/2 = 1/32$$

For (3) it is the sum of (1) and (2) = $1/16$

For (4) it is $1 - (\text{part 3}) = 1 - 1/16 = 15/16$

- 49.** The accompanying pedigree shows the pattern of transmission of two rare human phenotypes: cataract and pituitary dwarfism. Family members with cataract are shown with a solid left half of the symbol; those with pituitary dwarfism are indicated by a solid right half.

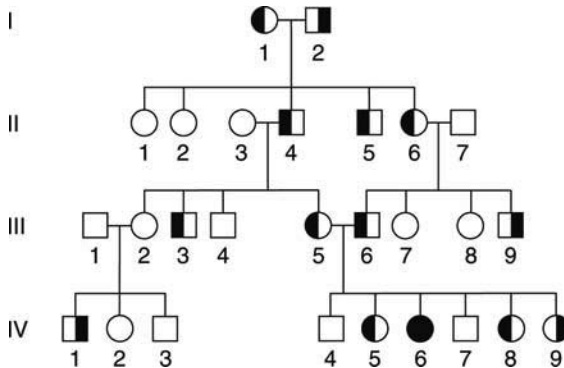

- What is the most likely mode of inheritance of each of these phenotypes? Explain.
- List the genotypes of all members in generation III as far as possible.
- If a hypothetical mating took place between IV-1 and IV-5, what is the probability of the first child's being a dwarf with cataracts? A phenotypically normal child?

(Problem 49 is after J. Kuspira and R. Bhambhani, *Compendium of Problems in Genetics*. Copyright 1994 by Wm. C. Brown.)

Answer:

- a. Cataracts appear to be caused by a dominant allele because affected people have affected parents. Dwarfism appears to be caused by a recessive allele because affected people have unaffected parents. Both traits appear to be autosomal.
- b. Using A for cataracts, a for no cataracts, B for normal height, and b for dwarfism, the genotypes are:

III : $a/a ; B/b, a/a ; B/b, A/a ; B/-, a/a ; B/-, A/a ; B/b, A/a ; B/b, a/a ; B/-, a/a ; B/-, a/a ; b/b$

- c. The mating is $a/a ; b/b$ (IV-1) \times $A/- ; B/-$ (IV-5). Recall that the probability of a child's being affected by any disease is a function of the probability of each parent carrying the allele in question and the probability that one parent (for a dominant disorder) or both parents (for a recessive disorder) donate it to the child. Individual IV-1 is homozygous for these two genes, therefore, the only task is to determine the probabilities associated with individual IV-5.

The probability that individual IV-5 is heterozygous for dwarfism is $2/3$. Thus the probability that she has the b allele and will pass it to her child is $2/3 \times 1/2 = 1/3$.

The probability that individual IV-5 is homozygous for cataracts is $1/3$; the probability that she is heterozygous is $2/3$. If she is homozygous for the allele that causes cataracts, she must pass it to her child or if she is heterozygous for cataracts, she has a probability of $1/2$ of passing it to her child.

The probability that the first child is a dwarf with cataracts is the probability that the child inherits the A and b alleles from its mother which is $(1/3 \times 1)(2/3 \times 1/2) + (2/3 \times 1/2)(2/3 \times 1/2) = 2/9$. Alternatively, you can calculate the chance of inheriting the b allele ($2/3 \times 1/2$) and not inheriting the a allele ($1 - 1/3$) or $1/3 \times 2/3 = 2/9$.

The probability of having a phenotypically normal child is the probability that the mother donates the a and B (or not b) alleles, which is $(2/3 \times 1/2)(1 - 1/3) = 2/9$.

50. A corn geneticist has three pure lines of genotypes $a/a ; B/B ; C/C, A/A ; b/b ; C/C,$ and $A/A ; B/B ; c/c$. All the phenotypes determined by $a, b,$ and c will increase the market value of the corn; so, naturally, he wants to combine them all in one pure line of genotype $a/a ; b/b ; c/c$.

- Outline an effective crossing program that can be used to obtain the $a/a ; b/b ; c/c$ pure line.
- At each stage, state exactly which phenotypes will be selected and give their expected frequencies.
- Is there more than one way to obtain the desired genotype? Which is the best way?

Assume independent assortment of the three gene pairs. (**Note:** Corn will self- or cross-pollinate easily.)

Answer:

a. and b. Begin with any two of the three lines and cross them. If, for example, you began with $a/a ; B/B ; C/C \times A/A ; b/b ; C/C$, the progeny would all be $A/a ; B/b ; C/C$. Crossing two of these would yield:

9	$A/- ; B/- ; C/C$
3	$a/a ; B/- ; C/C$
3	$A/- ; b/b ; C/C$
1	$a/a ; b/b ; C/C$

The $a/a ; b/b ; C/C$ genotype has two of the genes in a homozygous recessive state and occurs in 1/16 of the offspring. If that were crossed with $A/A ; B/B ; c/c$, the progeny would all be $A/a ; B/b ; C/c$. Crossing two of them (or “selfing”) would lead to a 27:9:9:9:3:3:3:1 ratio, and the plant occurring in 1/64 of the progeny would be the desired $a/a ; b/b ; c/c$.

There are several different routes to obtaining $a/a ; b/b ; c/c$, but the one outlined above requires only four crosses.

51. In humans, color vision depends on genes encoding three pigments. The R (red pigment) and G (green pigment) genes are close together on the X chromosome, whereas the B (blue pigment) gene is autosomal. A recessive mutation in any one of these genes can cause color blindness. Suppose that a color-blind man married a woman with normal color vision. The four sons from this marriage were color-blind, and the five daughters were normal. Specify the most likely genotypes of both parents and their children, explaining your reasoning. (A pedigree drawing will probably be helpful.) (Problem 51 is by Rosemary Redfield.)

Answer: First, draw the pedigree.

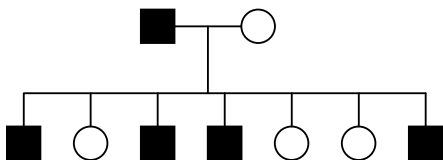

Let the genes be designated by the pigment produced by the normal allele : red pigment, R ; green pigment, G ; and blue pigment, B .

Recall that the sole X in males comes from the mother, while females obtain an X from each parent. Also recall that a difference in phenotype between sons and daughters is usually due to an X-linked gene. Because all the sons are colorblind and neither the mother nor the daughters are, the mother must carry a different allele for colorblindness on each X chromosome. In other words, she is heterozygous for both X-linked genes, and they are in repulsion: $R\ g/r\ G$. With regard to the autosomal gene, she must be $B/-$.

Because all the daughters are normal, the father, who is color-blind, must be able to complement the defects in the mother with regard to his X chromosome. Because he has only one X with which to do so, his genotype must be $R\ G/Y ; b/b$. Likewise, the mother must be able to complement the father's defect, so she must be B/B .

The original cross is therefore:

$$P \quad R\ g/r\ G ; B/B \times R\ G/Y ; b/b$$

F_1	Females	Males
	$R\ g/R\ G ; B/b$	$R\ g/Y ; B/b$
	$r\ G/R\ G ; B/b$	$r\ G/Y ; B/b$

52. Consider the accompanying pedigree for a rare human muscle disease.

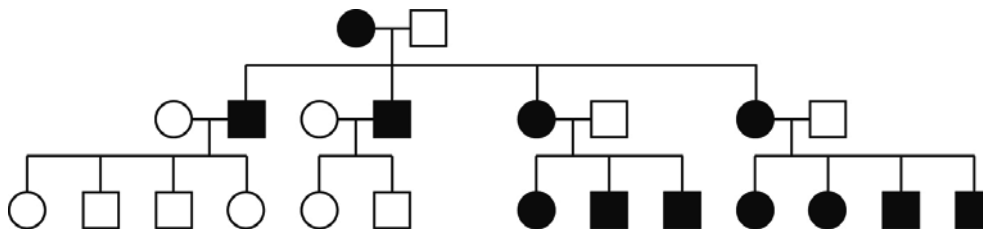

- a. What unusual feature distinguishes this pedigree from those studied earlier in this chapter?
- b. Where do you think the mutant DNA responsible for this phenotype resides in the cell?

Answer:

- a. The pedigree clearly shows maternal inheritance.
- b. Most likely, the mutant DNA is mitochondrial.

53. The plant *Haplopappus gracilis* has a $2n$ of 4. A diploid cell culture was established and, at premitotic S phase, a radioactive nucleotide was added and was incorporated into newly synthesized DNA. The cells were then removed

from the radioactivity, washed, and allowed to proceed through mitosis. Radioactive chromosomes or chromatids can be detected by placing photographic emulsion on the cells; radioactive chromosomes or chromatids appeared covered with spots of silver from the emulsion. (The chromosomes “take their own photograph.”) Draw the chromosomes at prophase and telophase of the first and second mitotic divisions after the radioactive treatment. If they are radioactive, show it in your diagram. If there are several possibilities, show them, too.

Answer: In the following schematic drawings, chromosomes (or chromatids) that are radioactive are indicated by the grains that would be observed after radioautography. After the second mitotic division, a number of outcomes are possible due to the random alignment and separation of the radioactive and non-radioactive chromatids.

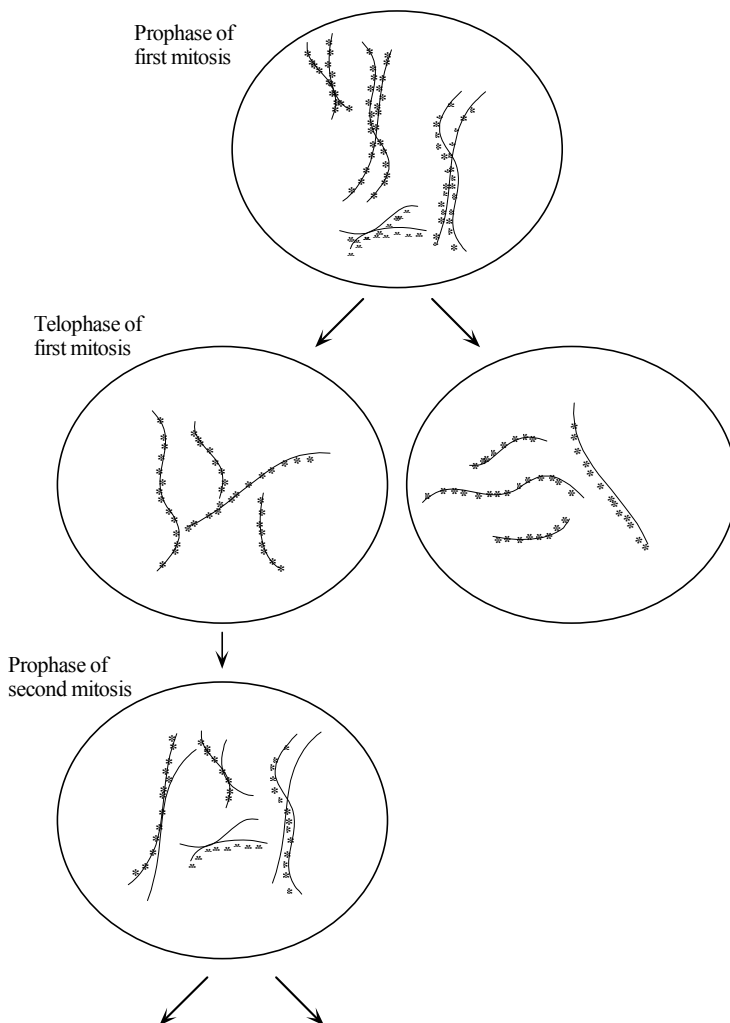

Telophase of second mitosis

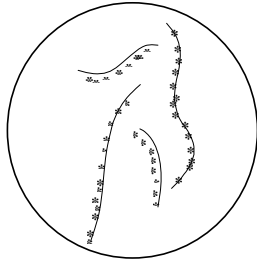

and

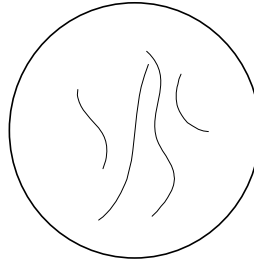

Probability

$1/8$

OR

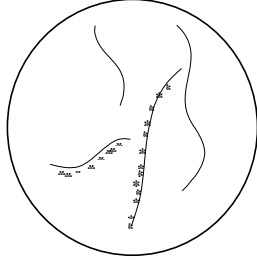

and

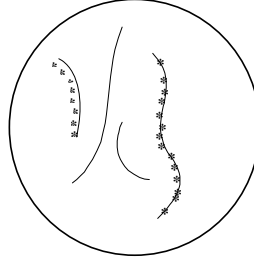

$1/4$

OR

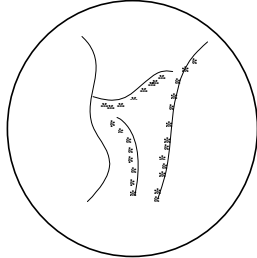

and

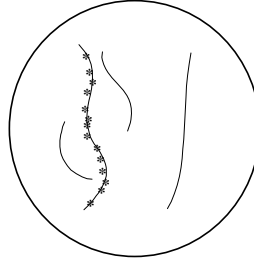

$1/4$

OR

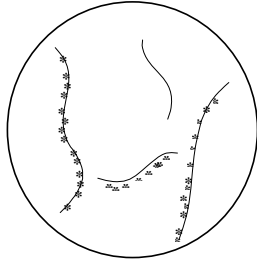

and

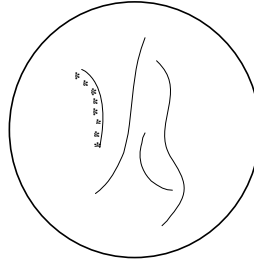

$1/4$

OR

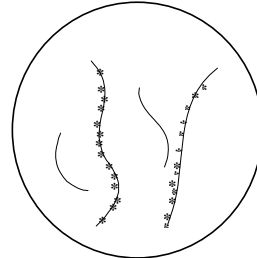

and

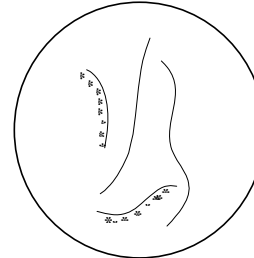

$1/8$

54. In the species of Problem 53, you can introduce radioactivity by injection into the anthers at the S phase before meiosis. Draw the four products of meiosis with their chromosomes and show which are radioactive.

Answer:

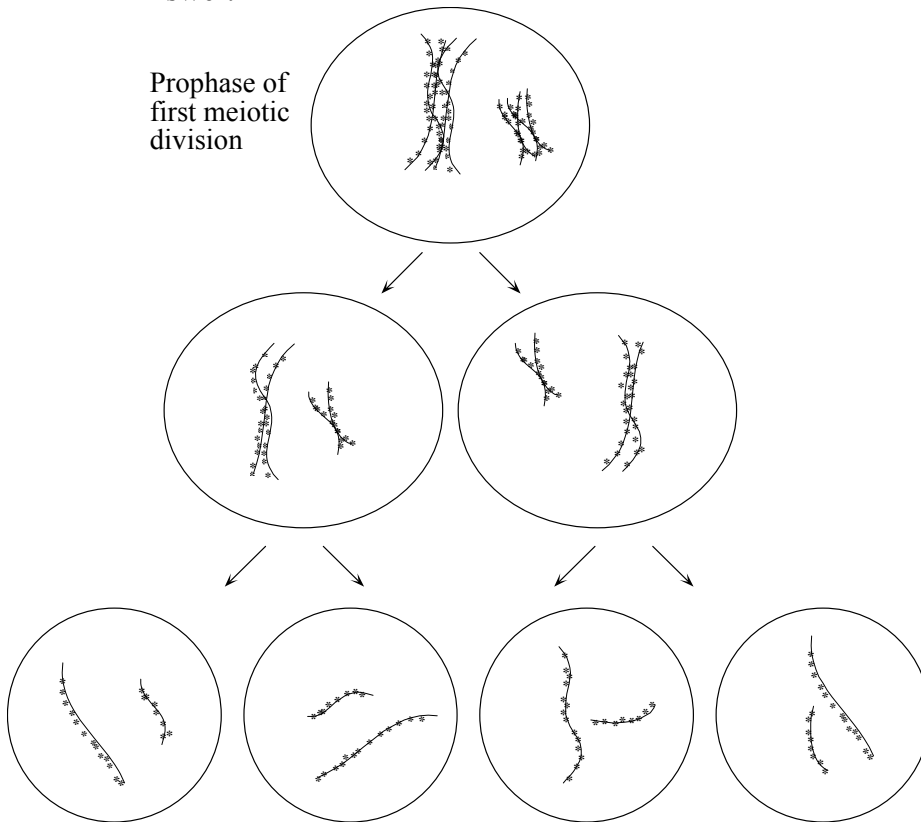

55. The DNA double helices of chromosomes can be partly unwound in situ by special treatments. What pattern of radioactivity is expected if such a preparation is bathed in a radioactive probe for
- a unique gene?
 - dispersed repetitive DNA?
 - ribosomal DNA?
 - telomeric DNA?
 - simple-repeat heterochromatic DNA?

Answer:

- In a diploid cell, expect two chromosomes (a pair of homologs) to each have a single locus of radioactivity.
- Expect many regions of radioactivity scattered throughout the chromosomes. The exact number and pattern would be dependent on the specific sequence in question, and where and how often it is present within the genome.
- The multiple copies of the genes for ribosomal RNA are organized into large tandem arrays called nucleolar organizers (NO). Therefore, expect

broader areas of radioactivity compared to (a). The number of these regions would equal the number of NO present in the organism.

- d. Each chromosome end would be labeled by telomeric DNA.
- e. The multiple repeats of this heterochromatic DNA are organized into large tandem arrays. Therefore, expect broader areas of radioactivity compared to (a). Also, there may be more than one area in the genome of the same simple repeat.
56. If genomic DNA is cut with a restriction enzyme and fractionated by size by electrophoresis, what pattern of Southern hybridization is expected for the probes cited in Problem 55?

Answer: The following is meant to be examples of what is possible. It is also possible, for instance, that more than one band would be present in (a), depending on the position of the restriction sites within the sequence complementary to the probe used.

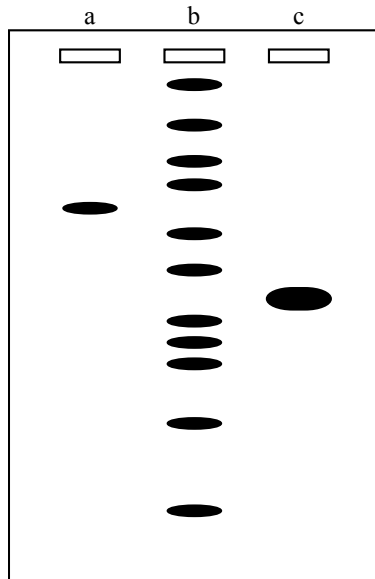

For (d) and (e), the specifics of where the DNA is cut relative to the telomeric DNA or heterochromatic DNA will effect what is observed. Assuming the restriction sites are not within the telomeric or heterochromatic DNA, then (d) will be similar to (b), and (c) will have one or several very large bands.

57. The plant *Haplopappus gracilis* is diploid and $2n = 4$. There are one long pair and one short pair of chromosomes. The diagrams below (numbered 1 through 12) represent anaphases (“pulling apart” stages) of individual cells in meiosis or mitosis in a plant that is genetically a dihybrid ($A/a ; B/b$) for genes on different

chromosomes. The lines represent chromosomes or chromatids, and the points of the V's represent centromeres. In each case, indicate if the diagram represents a cell in meiosis I, meiosis II, or mitosis. If a diagram shows an impossible situation, say so.

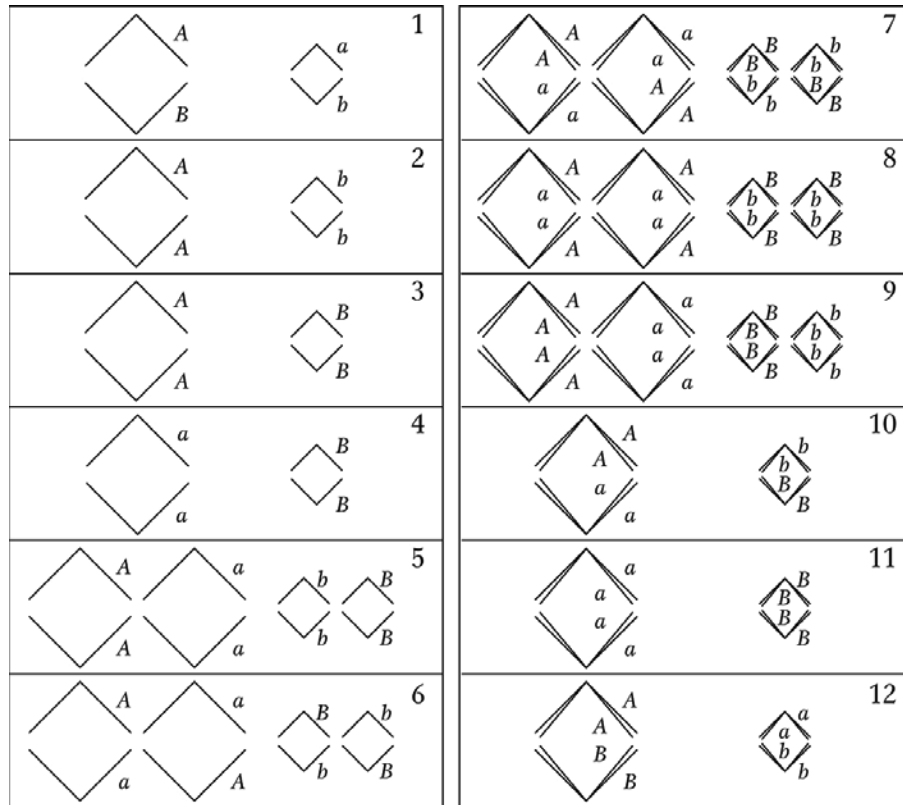

Answer:

- (1) Impossible: the alleles of the same genes are on nonhomologous chromosomes
- (2) Meiosis II
- (3) Meiosis II
- (4) Meiosis II
- (5) Mitosis
- (6) Impossible: appears to be mitotic anaphase but alleles of sister chromatids are not identical
- (7) Impossible: too many chromosomes
- (8) Impossible: too many chromosomes
- (9) Impossible: too many chromosomes
- (10) Meiosis I
- (11) Impossible: appears to be meiosis of homozygous a/a ; B/B
- (12) Impossible: the alleles of the same genes are on nonhomologous chromosomes

58. The pedigree below shows the recurrence of a rare neurological disease (large black symbols) and spontaneous fetal abortion (small black symbols) in one family. (A slash means that the individual is deceased.) Provide an explanation for this pedigree in regard to the cytoplasmic segregation of defective mitochondria.

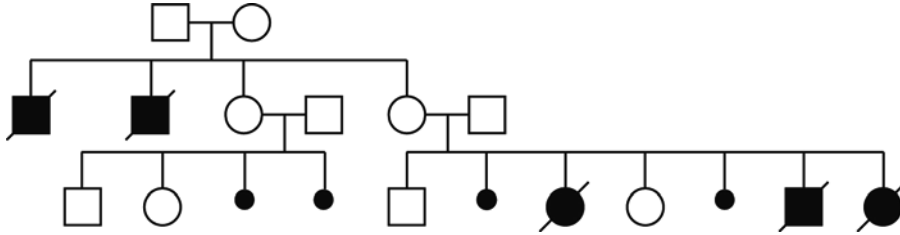

Answer: Recall that each cell has many mitochondria, each with numerous genomes. Also recall that cytoplasmic segregation is routinely found in mitochondrial mixtures within the same cell.

The best explanation for this pedigree is that the mother in generation I experienced a mutation in a single cell that was a progenitor of her egg cells (primordial germ cell). By chance alone, the two males with the disorder in the second generation were from egg cells that had experienced a great deal of cytoplasmic segregation prior to fertilization, while the two females in that generation received a mixture.

The spontaneous abortions that occurred for the first woman in generation II were the result of extensive cytoplasmic segregation in her primordial germ cells: aberrant mitochondria were retained. The spontaneous abortions of the second woman in generation II also came from such cells. The normal children of this woman were the result of extensive segregation in the opposite direction: normal mitochondria were retained. The affected children of this woman were from egg cells that had undergone less cytoplasmic segregation by the time of fertilization, so that they developed to term but still suffered from the disease.

59. A man is brachydactylous (very short fingers; rare autosomal dominant) and his wife is not. Both can taste the chemical phenylthiocarbamide (autosomal dominant; common allele), but their mothers could not.
- Give the genotypes of the couple.
If the genes assort independently and the couple has four children, what is the probability of
 - all of them being brachydactylous?
 - none being brachydactylous?
 - all of them being tasters?
 - ribosomal DNA?
 - telomeric DNA?
 - simple-repeat heterochromatic DNA?

- f. all of them being brachydactylous tasters?
- g. none being brachydactylous tasters?
- h. at least one being a brachydactylous taster?

Answer:

- a. Let B = brachydactylous, b = normal, T = taster and t = nontaster. The genotypes of the couple are B/b ; T/t for the male and b/b ; T/t for the female.
 - b. For all four children to be brachydactylous, the chance is $(1/2)^4 = 1/16$.
 - c. For none of the four children to be brachydactylous, the chance is $(1/2)^4 = 1/16$.
 - d. For all to be tasters, the chance is $(3/4)^4 = 81/256$.
 - e. For all to be nontasters, the chance is $(1/4)^4 = 1/256$.
 - f. For all to be brachydactylous tasters, the chance is $(1/2 \times 3/4)^4 = 81/4096$.
 - g. Not being a brachydactylous taster is the same $1 -$ (the chance of being a brachydactylous taster) or $1 - (1/2 \times 3/4) = 5/8$. The chance that all four children are not brachydactylous tasters is $(5/8)^4 = 625/4096$.
 - h. The chance that at least one is a brachydactylous taster is $1 -$ (the chance of none being a brachydactylous taster) or $1 - (5/8)^4$.
- 60.** One form of male sterility in corn is maternally transmitted. Plants of a male-sterile line crossed with normal pollen give male-sterile plants. In addition, some lines of corn are known to carry a dominant nuclear restorer allele (Rf) that restores pollen fertility in male-sterile lines.
- a. Research shows that the introduction of restorer alleles into male-sterile lines does not alter or affect the maintenance of the cytoplasmic factors for male sterility. What kind of research results would lead to such a conclusion?
 - b. A male-sterile plant is crossed with pollen from a plant homozygous for Rf . What is the genotype of the F_1 ? The phenotype?
 - c. The F_1 plants from part b are used as females in a testcross with pollen from a normal plant (rf/rf). What are the results of this testcross? Give genotypes and phenotypes, and designate the kind of cytoplasm.
 - d. The restorer allele already described can be called $Rf-1$. Another dominant restorer, $Rf-2$, has been found. $Rf-1$ and $Rf-2$ are located on different chromosomes. Either or both of the restorer alleles will give pollen fertility. With the use of a male-sterile plant as a tester, what will be the result of a cross in which the male parent is

- (i) heterozygous at both restorer loci?
- (ii) homozygous dominant at one restorer locus and homozygous recessive at the other?
- (iii) heterozygous at one restorer locus and homozygous recessive at the other?
- (iv) heterozygous at one restorer locus and homozygous dominant at the other?

Answer: For the following, S will signify cytoplasm of a male-sterile line and N will signify cytoplasm of a non-male-sterile line. *Rf* will signify the dominant nuclear restorer allele, and *rf* is the recessive non-restorer allele.

a. If S *rf/rf* (male-sterile plants) are crossed with pollen from N *Rf/Rf* plants, the offspring will all be S *Rf/rf* and male fertile. If these offspring are then crossed with pollen from N *rf/rf* plants, half the offspring will be S *Rf/rf* (male-fertile) and half will be S *rf/rf* (male-sterile). The S cytoplasm will not be altered or affected even though the maternal offspring parent plant was *Rf/rf*.

b. The cross is S *rf/rf* × N *Rf/Rf* so all the progeny will be S *Rf/rf* and male-fertile.

c. The cross is S *Rf/rf* × N *rf/rf* so half the progeny will be S *Rf/rf* (male-fertile) and half will be S *rf/rf* (male-sterile).

d.

- i. The cross is S *rf-1/rf-1 ; rf-2/rf-2* × N *Rf-1/rf-1 ; Rf-2/rf-2*
The progeny will be: 1/4 S *Rf-1/rf-1 ; Rf-2/rf-2* (male-fertile)
1/4 S *Rf-1/rf-1 ; rf-2/rf-2* (male-fertile)
1/4 S *rf-1/rf-1 ; Rf-2/rf-2* (male-fertile)
1/4 S *rf-1/rf-1 ; rf-2/rf-2* (male-sterile)
- ii. The cross is S *rf-1/rf-1 ; rf-2/rf-2* × N *Rf-1/Rf-1 ; rf-2/rf-2*
The progeny will all be: S *Rf-1/rf-1 ; rf-2/rf-2* (male-fertile)
- iii. The cross is S *rf-1/rf-1 ; rf-2/rf-2* × N *Rf-1/rf-1 ; rf-2/rf-2*
The progeny will be: 1/2 S *Rf-1/rf-1 ; rf-2/rf-2* (male-fertile)
1/2 S *rf-1/rf-1 ; rf-2/rf-2* (male-sterile)
- vi. The cross is S *rf-1/rf-1 ; rf-2/rf-2* × N *Rf-1/rf-1 ; Rf-2/Rf-2*
The progeny will be: 1/2 S *Rf-1/rf-1 ; Rf-2/rf-2* (male-fertile)
1/2 S *rf-1/rf-1 ; Rf-2/rf-2* (male-fertile)