

# Class Business:

Reading materials on course website

<http://fire.biol.wwu.edu/cmoyer/cmoyer.BI405.html>

Field trips (e.g. H<sub>2</sub>S scrubber at VRI and water treatment plant)  
- arrive early and stay late

# What is microbial ecology?



A microbial view of the world

"...the science that explores the interrelationships between microorganisms and their living (biotic) and nonliving (abiotic) environments" -- R. Atlas and R. Bartha, 1998

Ecology was a term first coined by Ernst Haeckel in 1866.  
*Oikos* (household/dwelling) + *logos* (law) → "law of the household"

**Microbial ecology** was a term that came into use in the 1960's.

# History of Microbiology

Antonie van Leeuwenhoek observes  
“animacules” (1676)

1600's

Spallazani argues against spontaneous  
generation of microbes (1768)

1700's

Needham argues for spontaneous  
generation of microbes (1745)

Saussure: oxidation of H<sub>2</sub> by soil,  
attributed to microbes (1839)

Pasteur: microbial  
fermentation (biodegradation  
of organic substances)  
(1857-1876)

Schloesing and Muntz:  
ammonium oxidation  
(nitrification) in sewage  
by passing through  
sand (1879)

Koch: isolation of pure  
cultures and Koch's  
postulates (1883-1884)

1800's

Fleming notices inhibition of  
Micrococcus by *Penicillium* factor (1929)

Carl Woese recognizes that  
Archaea are distinct from  
Bacteria (1977)

1900's

The first complete nucleotide sequence of a  
bacterial genome is completed (1995)

1866



“Work with impure cultures yields nothing but nonsense and *Penicillium glaucum*”

- Oscar Brefeld, 1881

An impure culture... horrors!

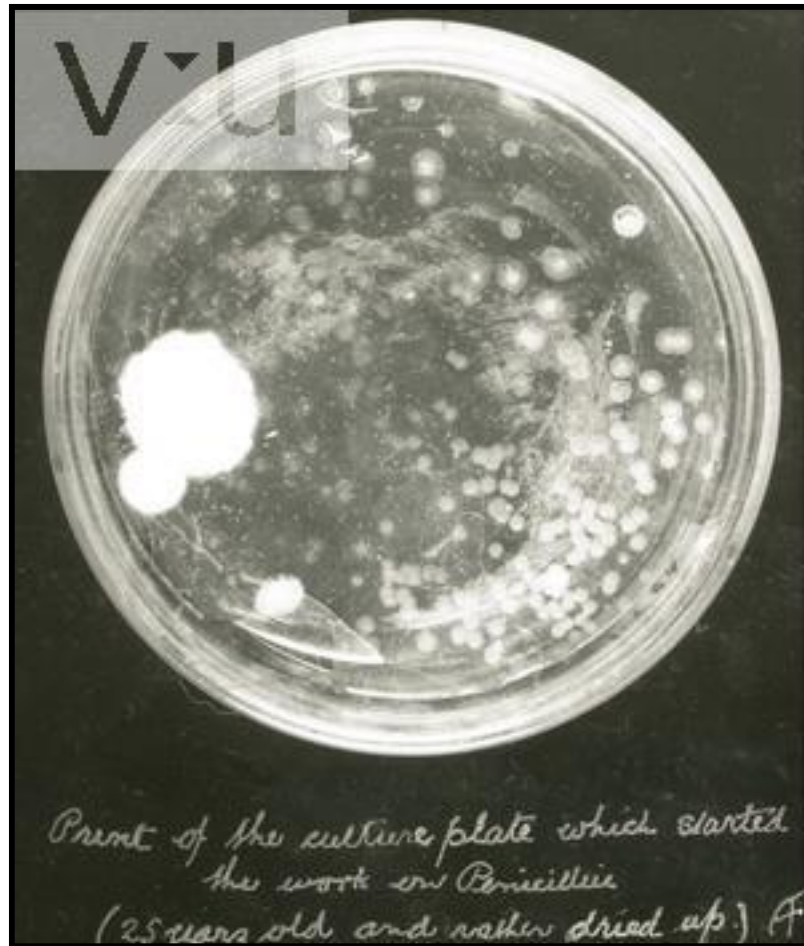

# Koch's Postulates

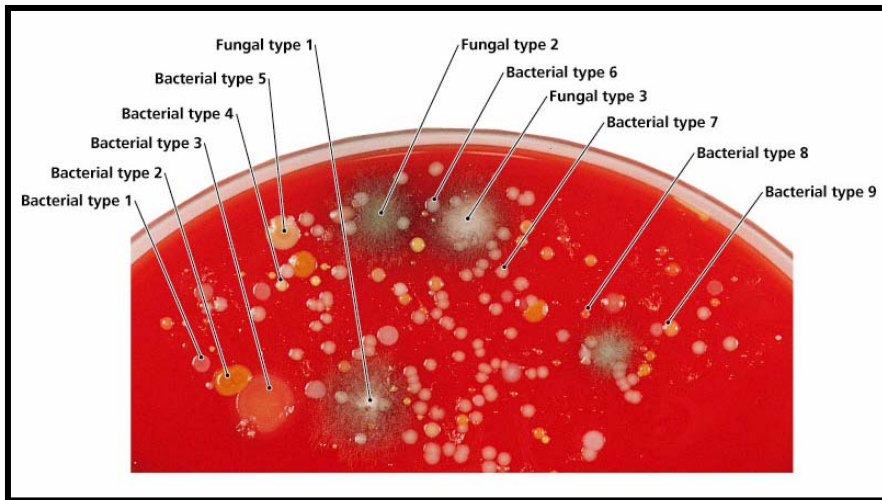

## Isolation of single colonies (pure cultures)

- Inference: each colony arose from a single cell
- Allowed isolation of purified bacterial agents
- Tested phenotype of purified bacterial agents by returning to **natural environment** (host)
- Problem: bacteria rarely exist in pure cultures in nature, so pure cultures are largely artificial!

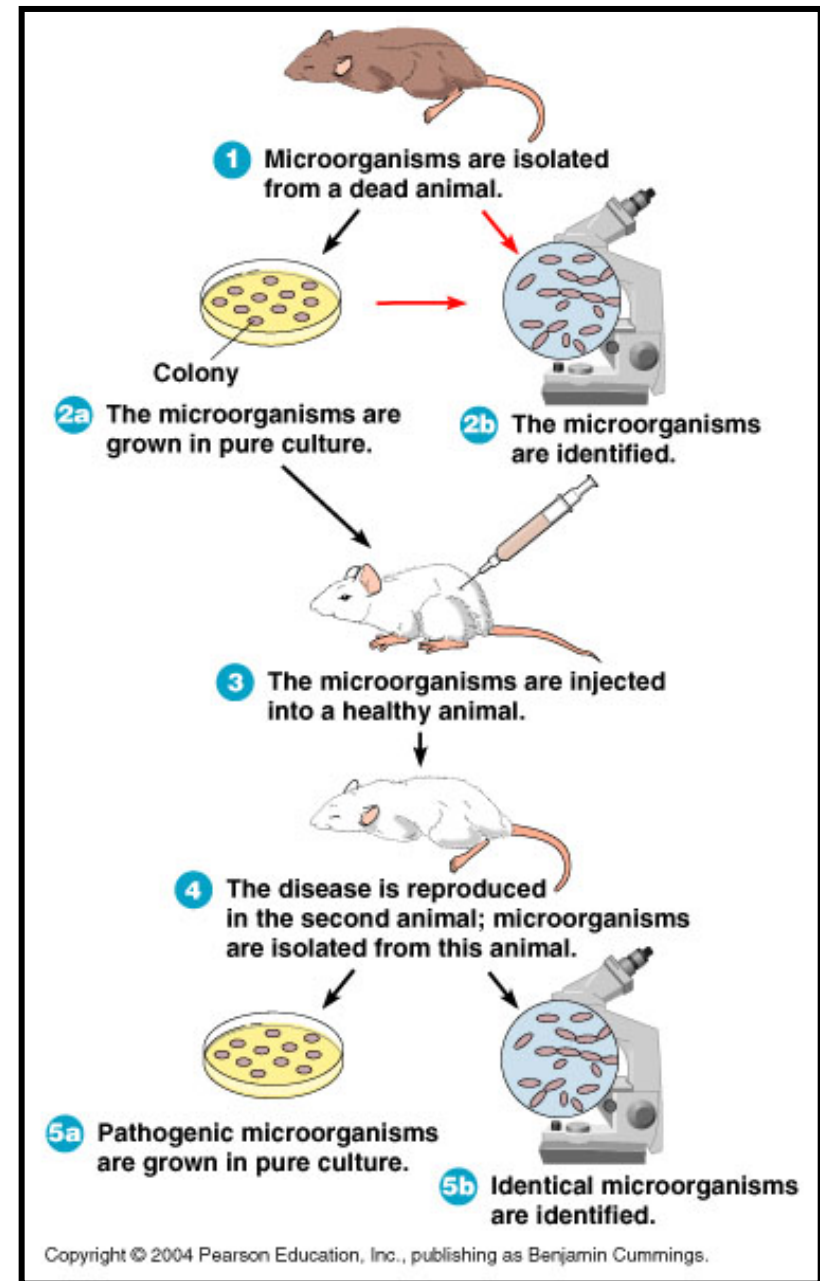

Dec 11. 28

20 24

### Inhibition by moulds.

Moulds plated on broth in flasks Nov 30. Room temp. (with window)

Equal parts ~~broth~~ mixed broth and boiling agar mixed and filled into holes in an agar plate. After solid. surface flooded with blood agar containing haemolytic streptococci. After 18 hours.

broth embedded.

1. Inhibition
2. *C. Jamie Viridescens*
3. *Bostry. cinerea*
4. *Aspergillus fumigatus*
5. *Penicillium*
6. *Sporobolium*

Inhibition of growth

- Complete for 5 mm round
- Partial only over embedded broth
- Nil
- Nil.
- Complete for 7 mm round.
- Nil.

When inhibition of streptococcal growth then blood capureses formed. Others laked.

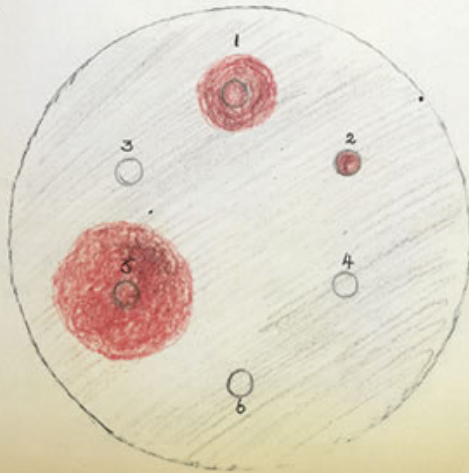

## Penicillium



# Sergei Winogradsky (1856-1953)

## Microbes in mixed communities

Fundamental contribution to microbial ecology:  
showed that bacteria are biogeochemical agents.

- Proposed concept of **chemoautotrophy**
- Showed that bacteria can oxidize iron, sulfur, and ammonia to obtain energy; showed that bacteria can incorporate  $CO_2$  into organic matter as do plants



# Sergei Winogradsky (1856-1953)

## Microbes in mixed communities

- Proposed concept of **chemoautotrophy**
  - Showed that bacteria can oxidize iron, sulfur, and ammonia to obtain energy; showed that bacteria can incorporate  $CO_2$  into organic matter as do plants

*Beggiatoa*: filamentous, gliding, sulfur-oxidizing bacteria. Found in habitats rich in  $H_2S$ : sulfur springs, decaying seaweed beds, rhizosphere of swamp plants, lake sediments, sewage, hydrothermal vents.

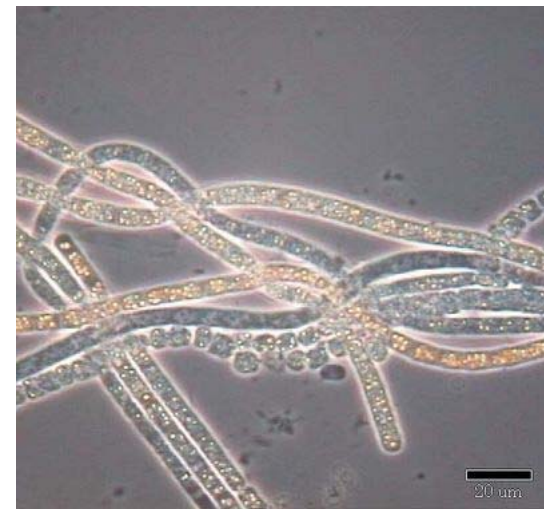
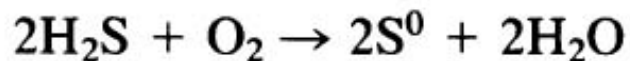

Filaments of *Beggiatoa*; the golden granules within the tubes are sulfur.



# Sergei Winogradsky (1856-1953)

## Microbes in mixed communities

Fundamental contribution to microbial ecology:

- Studied the **nitrogen cycle**
  - Nitrification,  $\text{NH}_4 \rightarrow \text{NO}_3$
  - Two-step process: *Nitrosomonas*, then *Nitrobacter* (isolated both)
- Described anaerobic bacterial  $\text{N}_2$ -fixation (*Clostridium pasteurianum*)

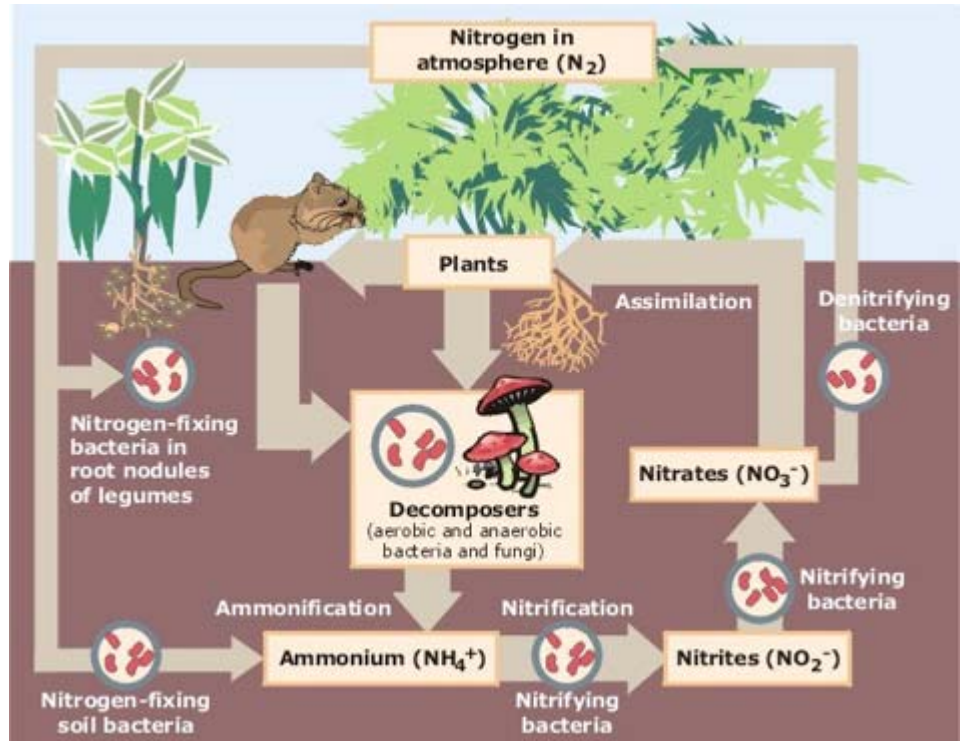

## Sergei Winogradsky: microbes in mixed communities (1856-1953)

**Winogradsky Column:** device for culturing a large diversity of microbes; pond sediment + carbon source + sulfur source + light; gradients of  $O_2$  and sulfide form selecting for various metabolic abilities.

Winogradsky believed soil microbes should be studied in their **natural environment** (soil).

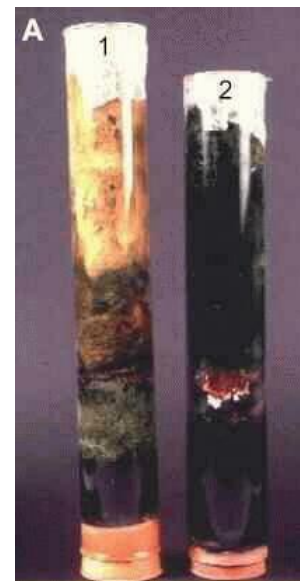
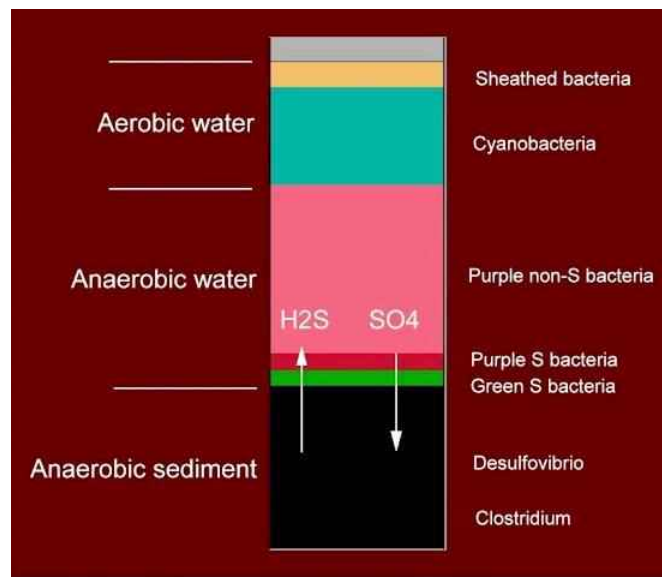

# History of Microbiology

Antonie van Leeuwenhoek observes  
“animacules” (1676)

1600's

Spallazani argues against spontaneous  
generation of microbes (1768)

1700's

Needham argues for spontaneous  
generation of microbes (1745)

Saussure: oxidation of  $H_2$  by soil,  
attributed to microbes (1839)

Pasteur: microbial  
fermentation (biodegradation  
of organic substances)  
(1857-1876)

Schloesing and Muntz:  
ammonium oxidation  
(nitrification) in sewage  
by passing through  
sand (1879)

Koch: isolation of pure  
cultures and Koch's  
postulates (1883-1884)

1800's

Fleming notices inhibition of  
Micrococcus by *Penicillium* factor (1929)

Carl Woese recognizes that  
Archaea are distinct from  
Bacteria (1977)

1900's

Winogradsky isolates nitrifying  
bacteria, describes oxidation of  
ferrous iron,  $H_2S$ , S: 1887-1890

The first complete nucleotide sequence of a  
bacterial genome is completed (1995)

## Martinus Beijerinck: Microbes in mixed communities (1851-1931)



Described aerobic  $N_2$  fixation (*Azotobacter*, *Rhizobium*)

Also introduced the idea of using **enrichment culture** to select for certain microbes:

Isolate natural samples in a selective fashion, with careful attention to nutrient and incubation requirements. Isolated:

- sulfate-reducers
- sulfur-oxidizers
- nitrogen fixers
- green algae
- etc.

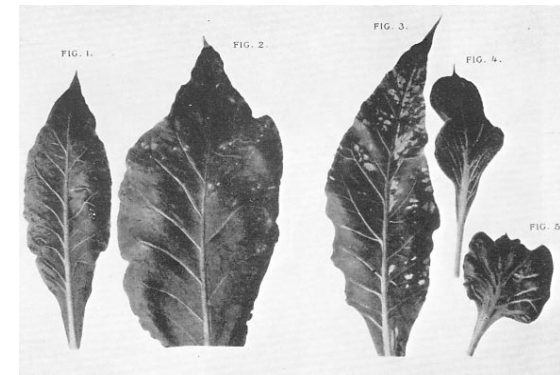

Also isolated tobacco mosaic virus - "contagious living fluid"

Watercolors of Martinus Willem Beijerinck's observations, by himself and his sister Henriëtte Wilhelmina (~ 1880-1920)

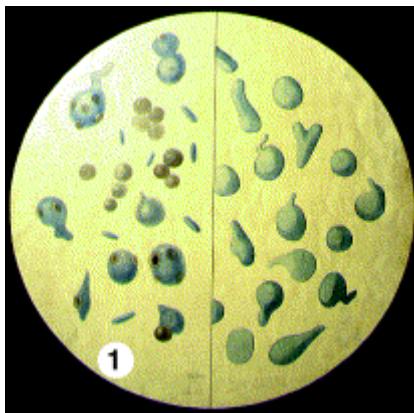

*Bacillus* (now *Bradyrhizobium*)  
*radicum*, isolated from the  
root nodules of *Vicia faba*

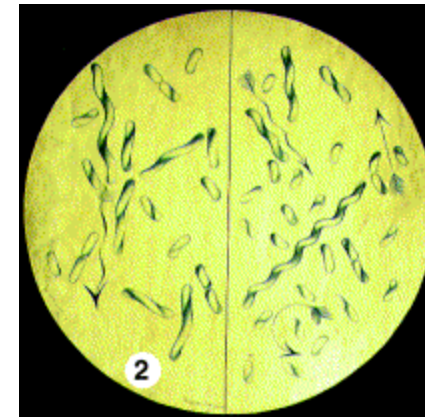

*Photobacterium luminosum*, a  
symbiont of luminescent fish  
in the deep North Sea

# History of Microbiology

Antonie van Leeuwenhoek observes  
“animacules” (1676)

1600's

Spallazani argues against spontaneous  
generation of microbes (1768)

1700's

Needham argues for spontaneous  
generation of microbes (1745)

Saussure: oxidation of H<sub>2</sub> by soil,  
attributed to microbes (1839)

Pasteur: microbial  
fermentation (biodegradation  
of organic substances)  
(1857-1876)

Schloesing and Muntz:  
ammonium oxidation  
(nitrification) in sewage  
by passing through  
sand (1879)

Koch: isolation of pure  
cultures and Koch's  
postulates (1883-1884)

1800's

Fleming notices inhibition of  
Micrococcus by *Penicillium* factor (1929)

Carl Woese recognizes that  
Archaea are distinct from  
Bacteria (1977)

1900's

Beijerinck isolates agents of symbiotic and  
nonsymbiotic N fixation, and sulfate  
reducers: 1898-1901.

The first complete nucleotide sequence of a  
bacterial genome is completed (1995)

## Milestones in Microbial Ecology:

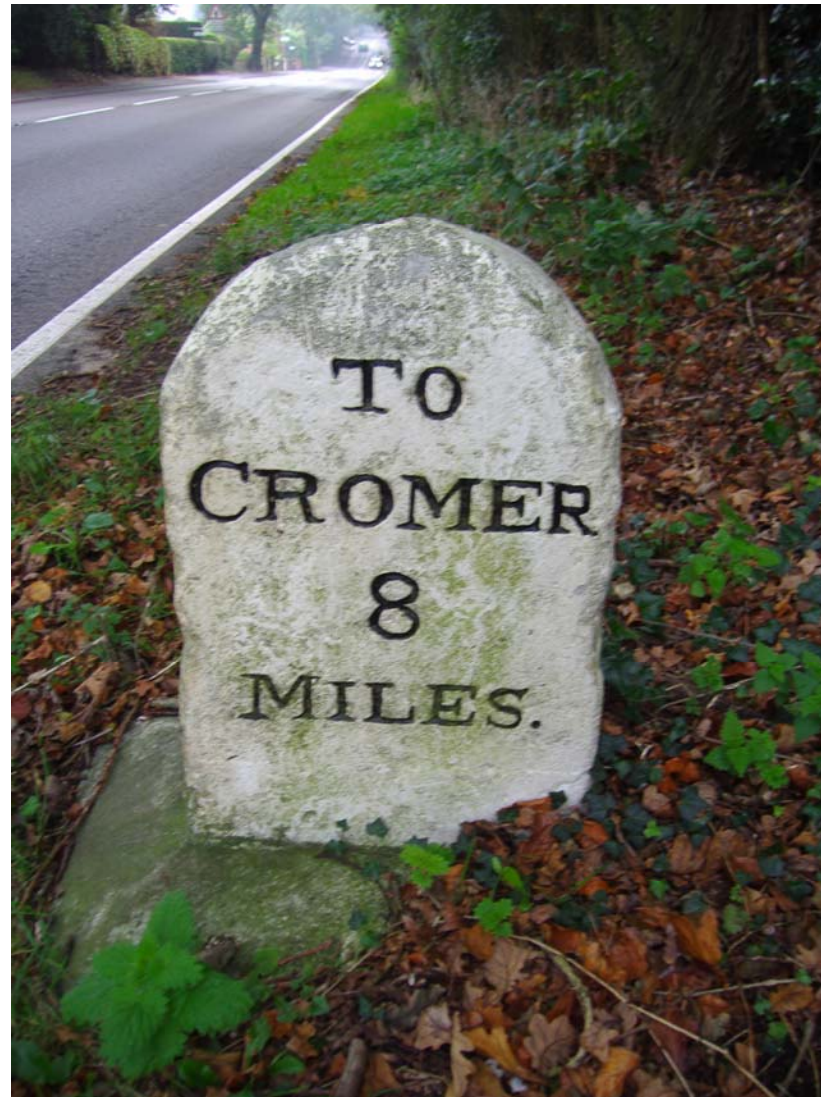

- 1887 Sergei Winogradsky studies *Beggiatoa* and establishes the concept of **autotrophy**.
- 1888 Martinus Beijerinck develops the technique of **enrichment culture**.
- 1891 Winogradsky discovers the organisms responsible for **nitrification** in soil, which is of great importance in agriculture because nitrogen is a limiting nutrient in the soil.
- 1904 Martinus Beijerinck obtains the first pure culture of sulfur-oxidizing bacterium, *Thiobacillus denitrificans*.
- 1904 Cornelius Johan Koning suggests that **fungi** are critical for the **decomposition** of organic matter.
- 1909 Sigurd Orla-Jensen proposes the use of **physiological characteristics** (vs. tiny round specks and tiny rod-shaped specks) for the classification of bacteria. He later publishes a monograph on lactic acid bacteria that establishes the criteria for assignment.
- 1920 The Society of American Bacteriologists presents a report on the characterization and classification of bacterial types that becomes the basis for **Bergey's manual** in 1923.



- 1965 Emile Zuckerkandl and Linus Pauling publish "**Molecules as documents of evolutionary history**", making a compelling case for the use of molecular sequences of biological molecules to determine evolutionary relationships.
- 1969 Don Brenner and colleagues establish a more reliable basis for the classification of clinical isolates among members of the *Enterobacteriaceae*. They use **nucleic acid reassociation**, where DNA of one organism is allowed to hybridize with another organism. This technique is used to help define a species.
- 1977 Carl Woese uses ribosomal RNA analysis to identify a third form of life, the **Archea**, whose genetic makeup is distinct from but related to both Bacteria and Eucarya.
- 1977 Discovery of abundant life at the bottom of the ocean near deep sea **hydrothermal vents**. The entire system is dependent upon sulfur oxidizing microorganisms. Light and photosynthesis do not drive the process.
- 1982 Karl Stetter isolates **hyperthermophilic microbes** (Archaea) that can grow at 105°C. The discovery redefines the upper temperature at which life can exist.
- 1994 Gary Olsen, Carl Woese and Ross Overbeek summarize the state of phylogeny in prokaryotes. This causes scientists to rethink the **classification of life** and emphasizes the importance of microbes.



# Leeuwenhoek and microscopy (1674)



Copyright © 2004 Pearson Education, Inc., publishing as Benjamin Cummings.

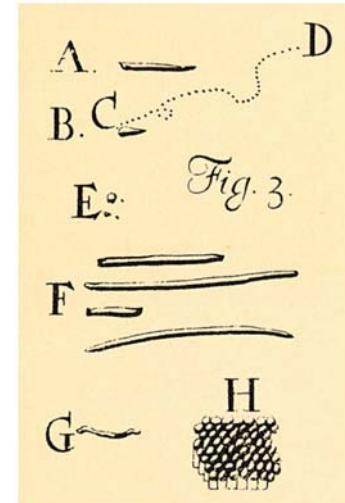
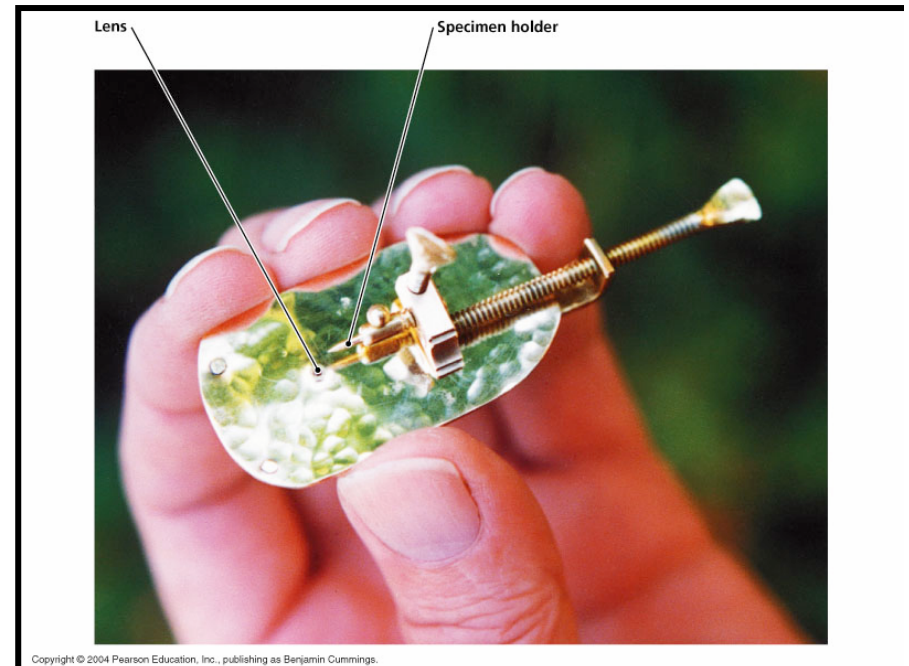

Figure 1-9b Brock Biology of Microorganisms 11/e  
© 2006 Pearson Prentice Hall, Inc.

- 1st observation of microorganisms (protozoa, bacteria)
- Plaque from teeth: "so many that I believe them to exceed the number of men in a kingdom" - AvL



Copyright © 2004 Pearson Education, Inc., publishing as Benjamin Cummings.

"A dead host is a dead end for most invaders too. Domesticating the host is the better long-term strategy for pathogens. We should think of each host and its parasites as a *superorganism* with the respective genomes yoked into a chimera of sorts. The power of this sociological development could not be more persuasively illustrated than by the case of mitochondria, the most successful of all microbes.

Perhaps one of the most important changes we can make is to supercede the 20th-century metaphor of war for describing the relationship between people and infectious agents. A more ecologically informed metaphor, which includes the germs'-eye view of infection, might be more fruitful. Consider that microbes occupy all of our body surfaces. Besides the disease-engendering colonizers of our skin, gut, and mucous membranes, we are host to a poorly catalogued ensemble of symbionts to which we pay scant attention. Yet they are equally part of the superorganism genome with which we engage the rest of the biosphere.

The protective role of our own microbial flora is attested to by the superinfections that often attend specific antibiotic therapy: The temporary decimation of our home-team microbes provides entrée for competitors. Understanding these phenomena affords openings for our advantage, akin to the ultimate exploitation by Dubos and Selman Waksman of intermicrobial competition in the soil for seeking early antibiotics. Research into the microbial ecology of our own bodies will undoubtedly yield similar fruit."

-- Joshua Lederberg. 2000. *Infectious History*. *Science* 288: 287 - 293

Joshua Lederberg heads the Laboratory of Molecular Genetics and Informatics at The Rockefeller University in New York City, and a Nobel laureate (1958) for his research on genetic mechanisms in bacteria. He has worked closely with the Institute of Medicine and the Centers for Disease Control and Prevention on analytical and policy studies on emerging infections.

# Gut microbes are correlated with many of our metabolic processes

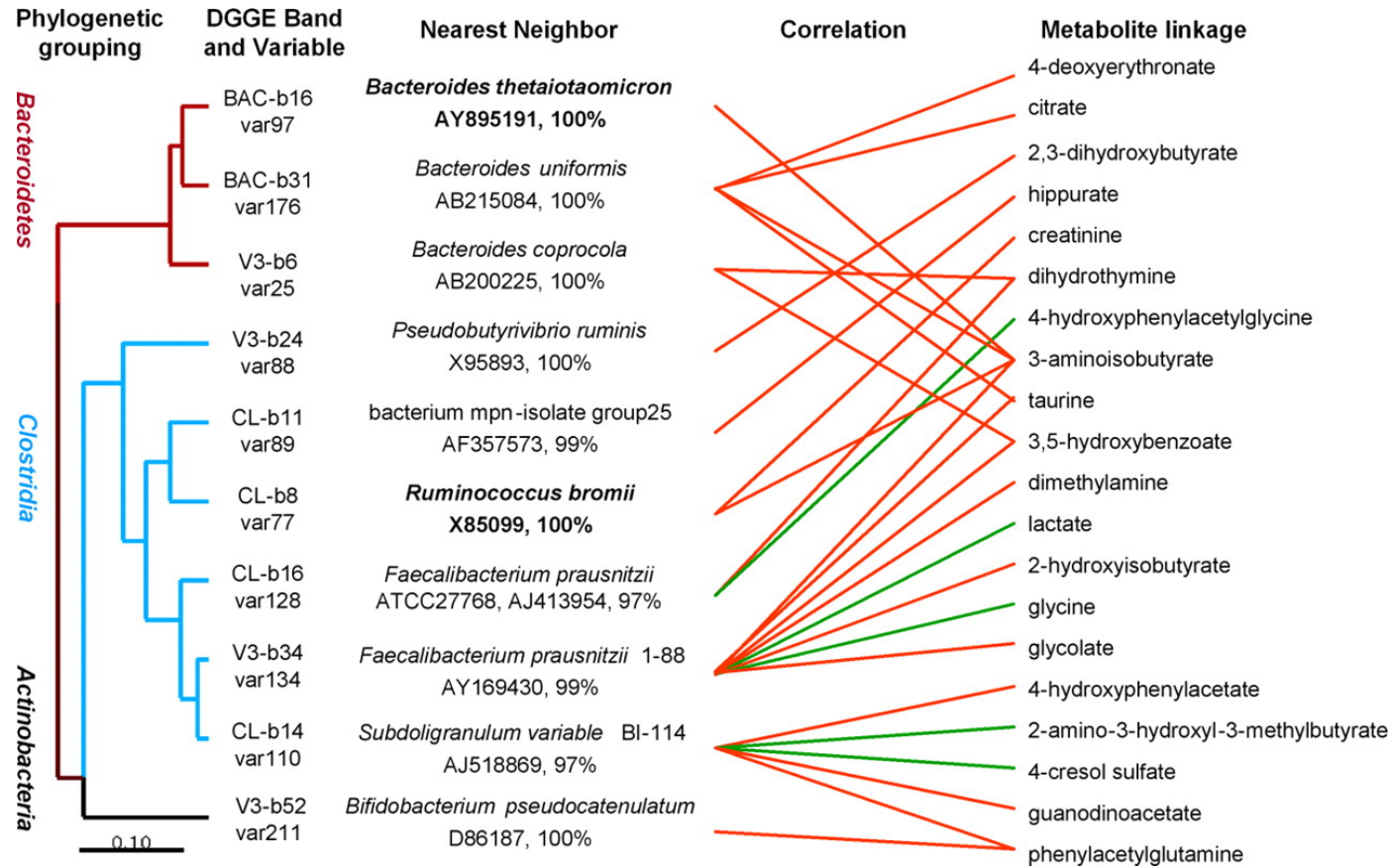

Dendrogram of OTUs from DGGE bands, which are well predicted by metabolic variation, labeled as the nearest known neighbor with similarity value

# Comparison of gut microbiome between individuals

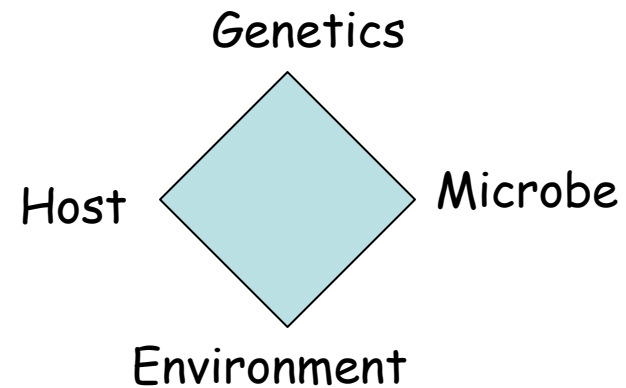
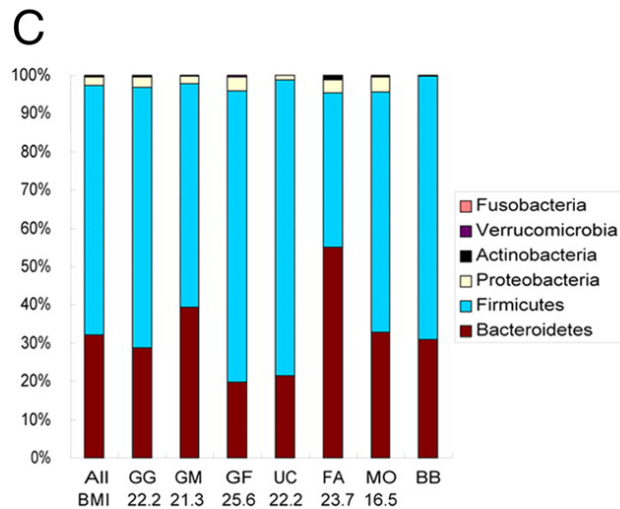
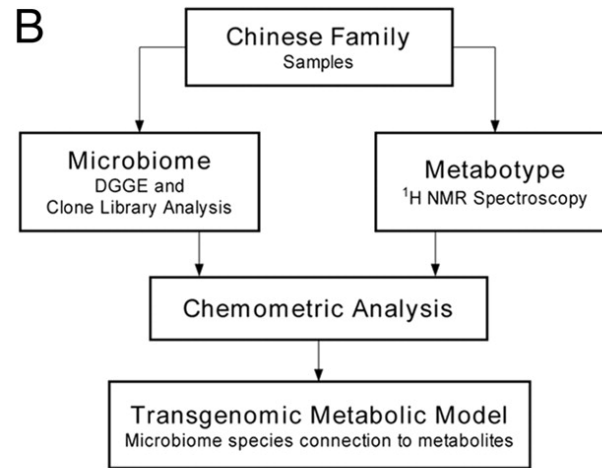
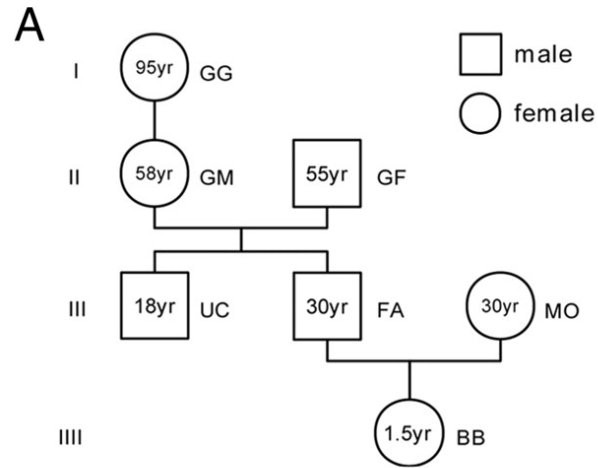

Proposal (Amer. Acad. Microbiology):

## **“Koch's Postulates for microbial communities”**

1. Gain an understanding of the environment, including **chemical processes and members**
2. **Acquire the isolates** that carry out these processes
3. **Return isolates to the environment** and demonstrate that they are responsible for the processes of interest

Deconstructing the community this way from constituent key players should **retain key characteristics and process rates** of the original.

# What is a microbe's environment?

**Key features:** liquid water, nutrients, and an energy producing system (including an electron donor and electron acceptor).

## Sources of energy:

Photons (photosynthesis)

Electrons (oxidation of reduced molecules, e.g. sugars, proteins, sulfur, iron, H<sub>2</sub>...)

## Acceptable e- acceptors:

Gaseous oxygen (like us), sulfate, nitrate, nitrite, carbon dioxide, carbon monoxide, iron and magnesium...

Desirable microbial real estate is varied, reflecting the diverse "tastes" of these wee fellow Earthlings:

Inside of or associated with eukaryotic cells (animals, plants, fungi)

At extreme temperatures (>100°C and as low as 0°C)

At extreme pH (<2.0 and <11.0)

Deep subsurface (3.5 km below the earth's surface)

In the presence of toxic metals like copper or mercury

In saturated salt solutions



## Below is an abbreviated list of the roles microbes play in our lives:

They maintain soil fertility and soil tilth.

They clean up all the dead organic material; without them we would be up to our ears in dead things, like our ancestors.

They fix gaseous nitrogen into forms that can be used by plants to maintain the fertility of soils .

They can be used to extract minerals from ores.

They are the prime food for all the marine and freshwater life; even whales depend on them directly or indirectly for their nutrition.

# Why study microbial ecology?

## **The philosopher:**

"Microbial ecology can show us our place in the cosmos -- how life originated and how it evolved, and how we are related to the great diversity of all other organisms."

## **The altruist:**

"The study of microbial ecology can help us improve our lives via the use of microbes in environmental restoration, food production, bioengineering of useful products such as antibiotics, food supplements, and chemicals."

## **The eternal student:**

"We likely know fewer than 1% of the microbial species on Earth. Yet microbes surround us everywhere -- air, water, soil. An average gram of soil contains one billion (1,000,000,000) microbes representing probably several thousand species. WOW!!! There is so much to learn..."

Microbial ecology is a broad umbrella encompassing a huge variety of skills and disciplines.



Undersea microbial mats (rust)



Plant-microbe interactions, good and bad

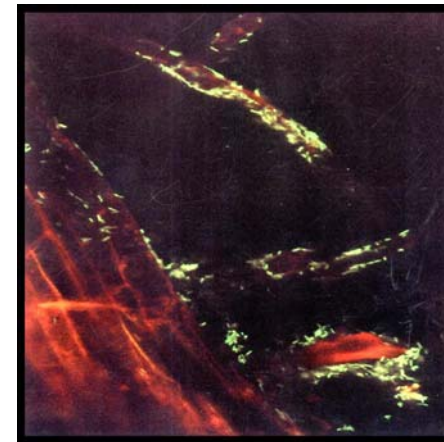

## Microbial ecology is the study of life itself...

How did we get here? The study of the origin and early evolution of microorganisms may provide information on the critical early stages of life. Microbes were the first living creatures on Earth, first appearing over 3.7 billion years ago - long before multicellular plants and animals, which evolved 600 million years ago.

Understanding the biology of microbes that live in conditions that we think might reflect those of a very young Planet Earth may provide insight into the origin of all life on Earth.

Studies of microbes also are fundamental in our current and ongoing understanding of the unifying principles of life (biochemistry, genetics, bioenergetics, evolution, ecology).

Work with microbial extremophiles gives us an idea about the actual chemical, physical, and genetic constraints beyond which life is not possible.

## Exobiology

Does life exist elsewhere in the universe? If there is life elsewhere in the universe, it is probably microbial.

While we may never know in our own lifetimes whether life exists elsewhere in the universe, microbes will probably play a key role in helping us explore and colonize space.

# Biodiversity

Many years of evolution have created a stunning diversity of microbes. But of the more than one million species of bacteria suspected to exist, only about 4200 species of bacteria are described. Major reason: failure to culture, perhaps due to:

- narrow habitat/niche of many microbes
- presence of trace contaminants
- presence of lysogenic phage
- not grown long enough
- lack of correct nutrients or incorrect levels thereof
- absence of signal molecules
- absence of microbe-microbe or host-microbe interactions

The infant science of microbial systematics has only recently acquired the sophisticated tools required to assess this tremendous biodiversity. It is estimated that we know less than 1% of the microbial species on Earth.

## Ecology

Using microbes to study ecology may provide clues to how complex ecosystems operate because bacteria are small so large populations can be studied and quick to reproduce compared to larger organisms (*e.g. Richard Lenski*). A better understanding of ecology may help us better manage Earth and its dwindling renewable resources, and to protect global ecological systems.

**Global Ecology** - Microbes play important global roles:

Global Biogeochemical Cycles: C, N, Fe, S

**Human Ecology** - The study of simple microbial communities may shed light on one of the more complex (and for most of us, fascinating) communities - the microbial community within a human being. We are hosts to billions of microbes which colonize our intestinal tracts, our skin, hair, teeth. Sometimes microbial colonization causes us problems when disease results. Some scientists have joked that humans are microbes' invention for getting around.

## Interdomain interactions

Microbes interact with eucaryotic hosts (e.g. plants and animals) in myriad ways. Plants and animals host hundreds of associations with different microbial species.

Examples:

*Rhizobium* converts dinitrogen to ammonium, a form of nitrogen that is available to plants.

Beneficial gut microflora (> 300 species)

Lichens



## **Bioremediation**

Environmental degradation is one of the worst threats facing humanity. Many environmental problems may be cured by microbes.

**Bioremediation of toxic wastes:** Microbes are the focus of many studies because of their metabolic diversity. They can degrade, and utilize, a huge variety of compounds. This ability is harnessed for cleanup of toxic wastes. Microbes are used to clean up the following:

- **Oil spills**
- **Pesticides**
- **Industrial wastes**

# Recycling

Microorganisms recycle most organic wastes in nature into reusable resources. If not for microbes, we'd be up to our ears (and more) in dead stuff...

Humans have harnessed the power of microbes to recycle in the systems below:

**Waste treatment:** Microbes are used in sewage treatment for nutrient recycling, methane recovery and disease control.

**Animal waste treatment:** Microbes transform waste produced by farm animals.

**Composting:** Composting is the now-fashionable practice of converting kitchen, yard, and municipal wastes into a rich soil amendment. Although worms have gotten good press for their contribution to composting, the real workhorses of composting are microbes.

## Food Microbiology

Fine line between food spoilage and fermentation... many bacterially fermented foods were likely discovered by ancestors who were truly hungry (couldn't throw out food).

Many of our foods are prepared with the aid of microbes, such as yeast in bread, and lactobacilli in yogurt. Culturally specific - pickled herring vs. fermented seal flipper, sauerkraut vs. kimchi.

Much of the protein that we eat is the result of bacterial fixation of nitrogen from the air from microbes such as *Rhizobium*.

Many of our food supplements, from vitamins, amino acids to flavor enhancers and preservatives, come from microbes.

Although not a food, microbes are used as probiotics, a digestion supplement that colonizes the intestines, preventing the colonization of bad, disease-causing microbes.

## Biotechnology

Microbes are used as workhorses in the production of many compounds, from fuel, to pharmaceuticals, to chemicals. They are also used in mining, insect and disease control, genetic engineering and some are even used to make computer biochips.

### Fuel Production

- digestion of corn and sugarcane polymers in the manufacture of ethanol for automobile fuel.
- microbial fuel cells

### Mining

- leaching of metals from ore-bearing rocks by microbes. 5% of world's copper ore is produced by bio-leaching. Uranium is mined with help of bacteria.

**Biocontrol** - Using microbes to combat pests is called biocontrol. One of the most popular forms of biocontrol is the use of *Bacillus thuriengensis*, a bacterium that produces a toxin that kills over 40 problem pests such as the gypsy moth.

**Genetic Engineering** - Some microorganisms are used to carry genes into other organisms.

- The bacterium *Agrobacterium tumefaciens* plays a key role in genetically engineering plants.

- The gene encoding the delta-endotoxin from *Bacillus thuringiensis* has been widely inserted into many crops to confer pest resistance

# The first question in exploring a habitat is often "Who's Out There"?

16 S rRNA, classical methods

How Many?

direct count (microscopic evaluation)  
viable count (what can be grown in lab)

How many of the direct count are viable?

Nalidixic acid assay, causes actively respiring cells to enlarge

Propidium monoazide: leaks into dead cell membranes and binds DNA - can't do PCR

Fluorescent Antibodies  
(Fluorescence *In Situ*  
Hybridization)

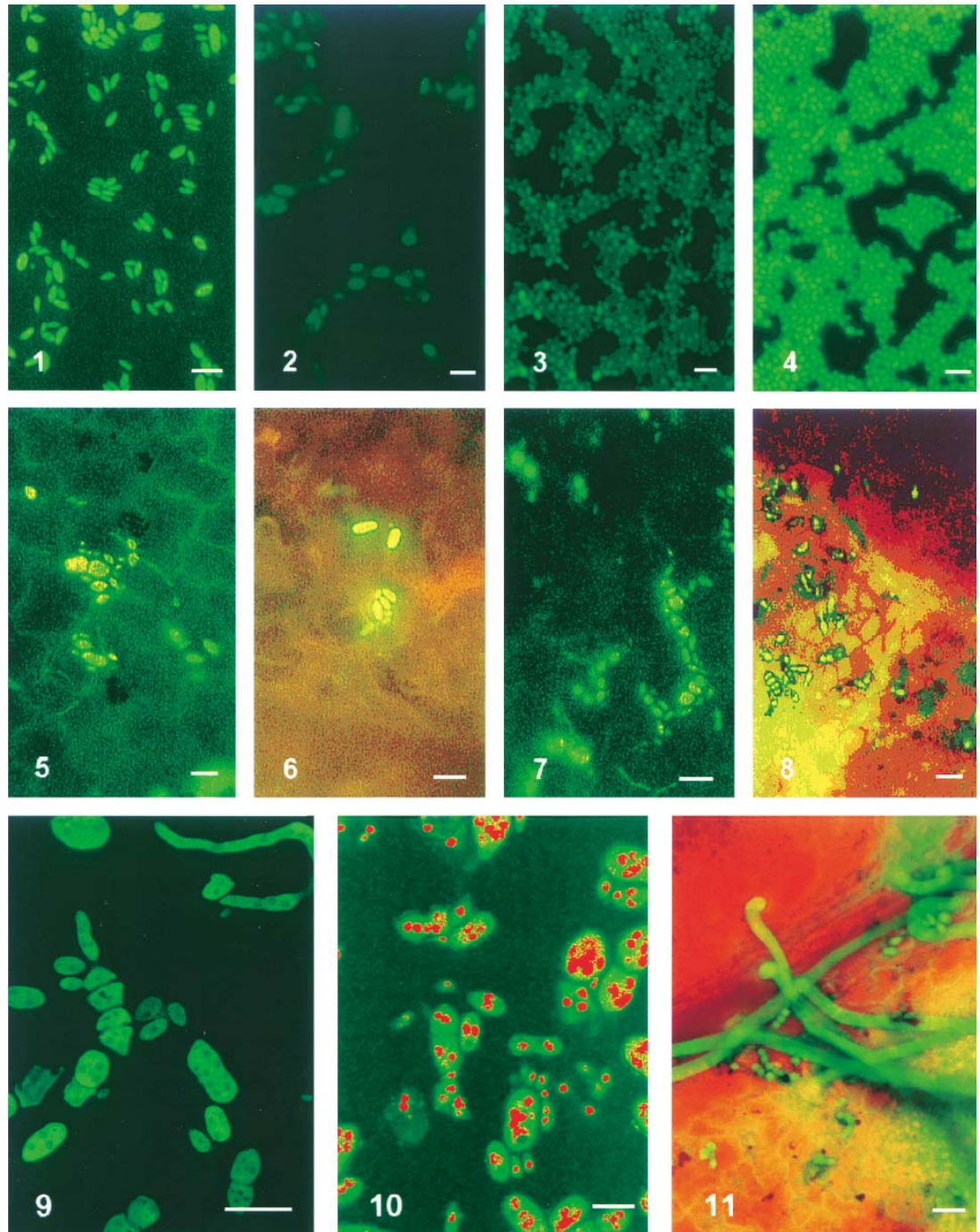



Who is doing what? How do we observe these wild creatures in their natural environment?

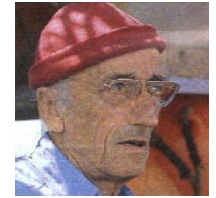

GFP to differentiate species or manifest gene expression.

Can combine FISH with mass spectrometry to determine which substrates are being assimilated

*Fusarium* infecting barley head

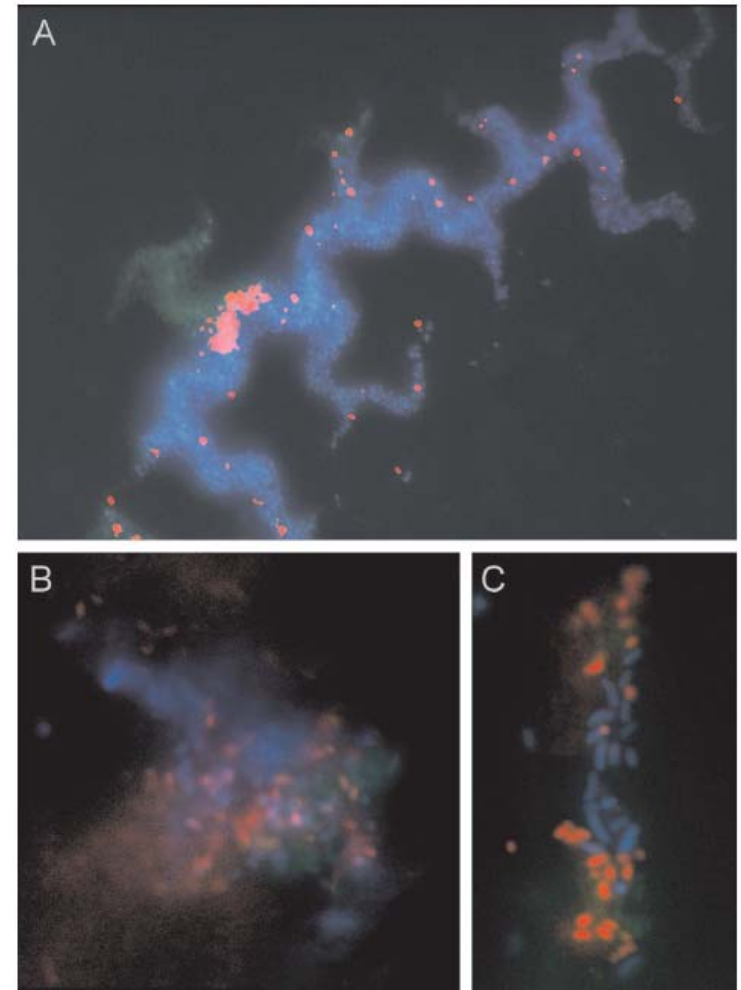
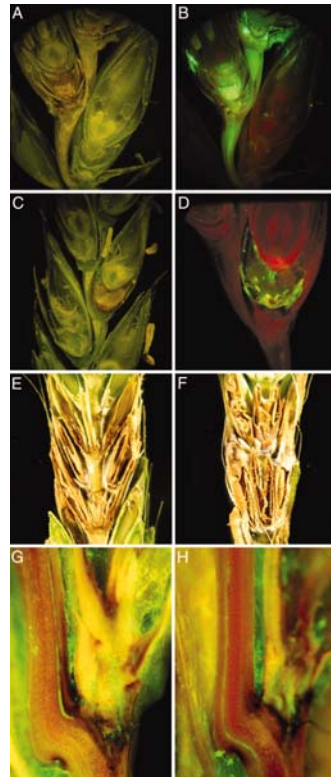

*Pseudomonas syringae* and *Pantoea agglomerans* on a bean leaf surface



Ecosystem: self-supporting system including organisms in a natural community, and their environment

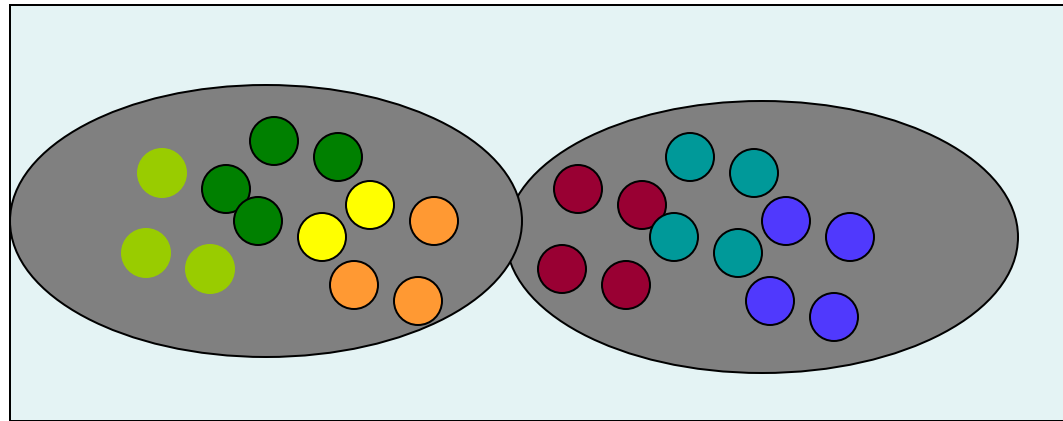

Community: interacting populations, each with its niche in the habitat

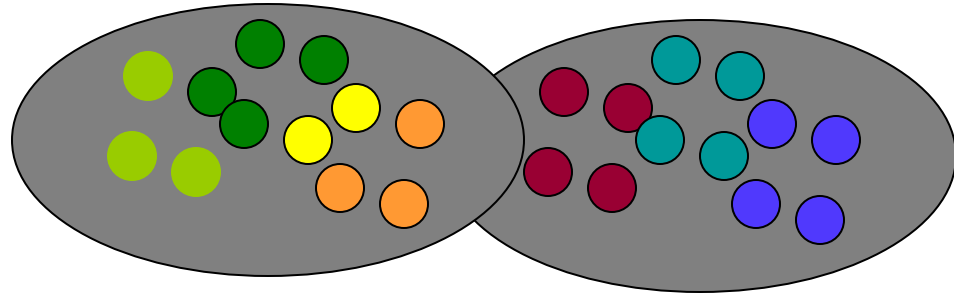

Guild: populations with similar nutritional and metabolic needs (methanogens, sulfur oxidizers, etc.)

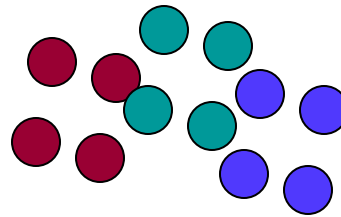

Synecology: interactions between various populations

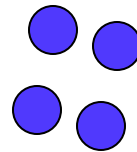

Population

Individual



Autecology: relationship between an individual and its environment

# Microbes: single celled, but not isolated

Most bacteria do not normally live in isolation from one another  
(Exception: *Vibrio* in squid light organ = pure culture)

**Consortia:** groups of bacteria that live together and often depend upon other consortia members to provide some or all of their nutrients

→ Is the "consortia effect" one reason we can grow such a relatively low number of bacteria as pure cultures in the lab?

**Guilds:** groups of bacteria that have similar nutritional and metabolic needs (methanogens, sulfur oxidizers, etc.)

**Indicator Species:** easily identified species that suggests the presence of its consortia - e.g., *E. coli* often serves as an indicator of fecal waste; in coastal waters, toxic algal blooms can also indicate *Vibrio cholerae*.

## Isolation and Initial Characterization of a Bacterial Consortium Able To Mineralize Fluorobenzene

M. F. Carvalho,<sup>1</sup> C. C. T. Alves,<sup>1</sup> M. I. M. Ferreira,<sup>1</sup> P. De Marco,<sup>2</sup> and P. M. L. Castro<sup>1\*</sup>

*Escola Superior de Biotecnologia, Universidade Católica Portuguesa, 4200-072 Porto,<sup>1</sup> and IBMC,  
Universidade do Porto, 4150-180 Porto,<sup>2</sup> Portugal*

Received 13 July 2001/Accepted 24 October 2001

# Biofilms

Complex three dimensional structures produced by single bacterial species or consortia; protected by secretion of extensive EPS

Examples:

*Pseudomonas aeruginosa* can form an extremely hard to treat biofilm on artificial joint surfaces

(essentially impervious to antibiotics; 10% of hip replacements will require surgery within 3 years because of *P. aeruginosa* biofilms)

Biofilms cost millions to remove from municipal water systems and can harbor disease causing bacteria that are protected from chlorine by the biofilm

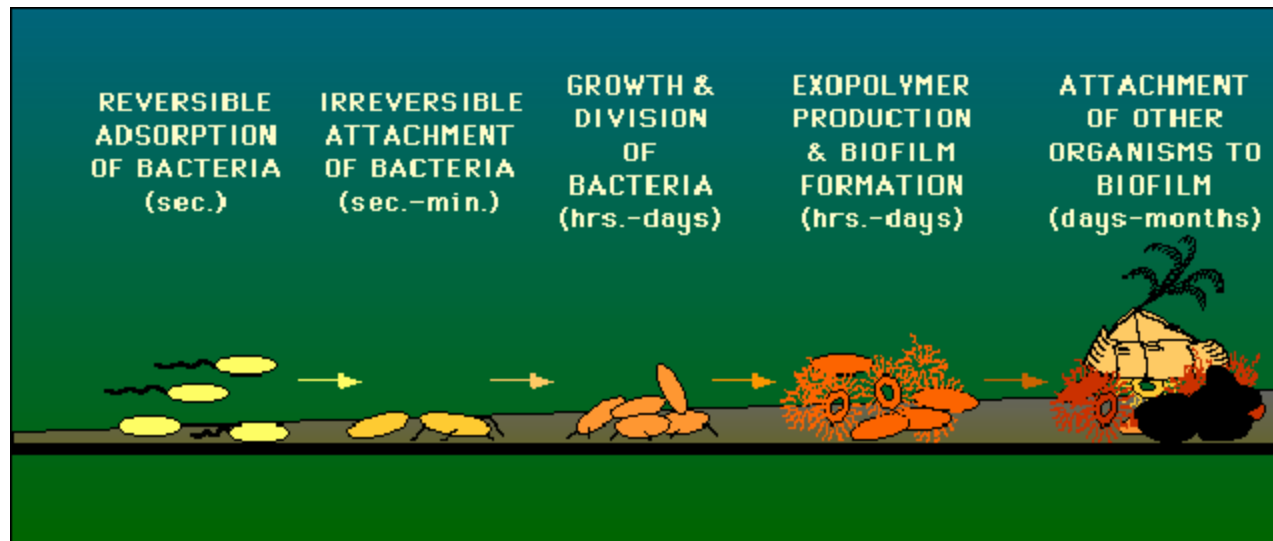

Biofilm succession

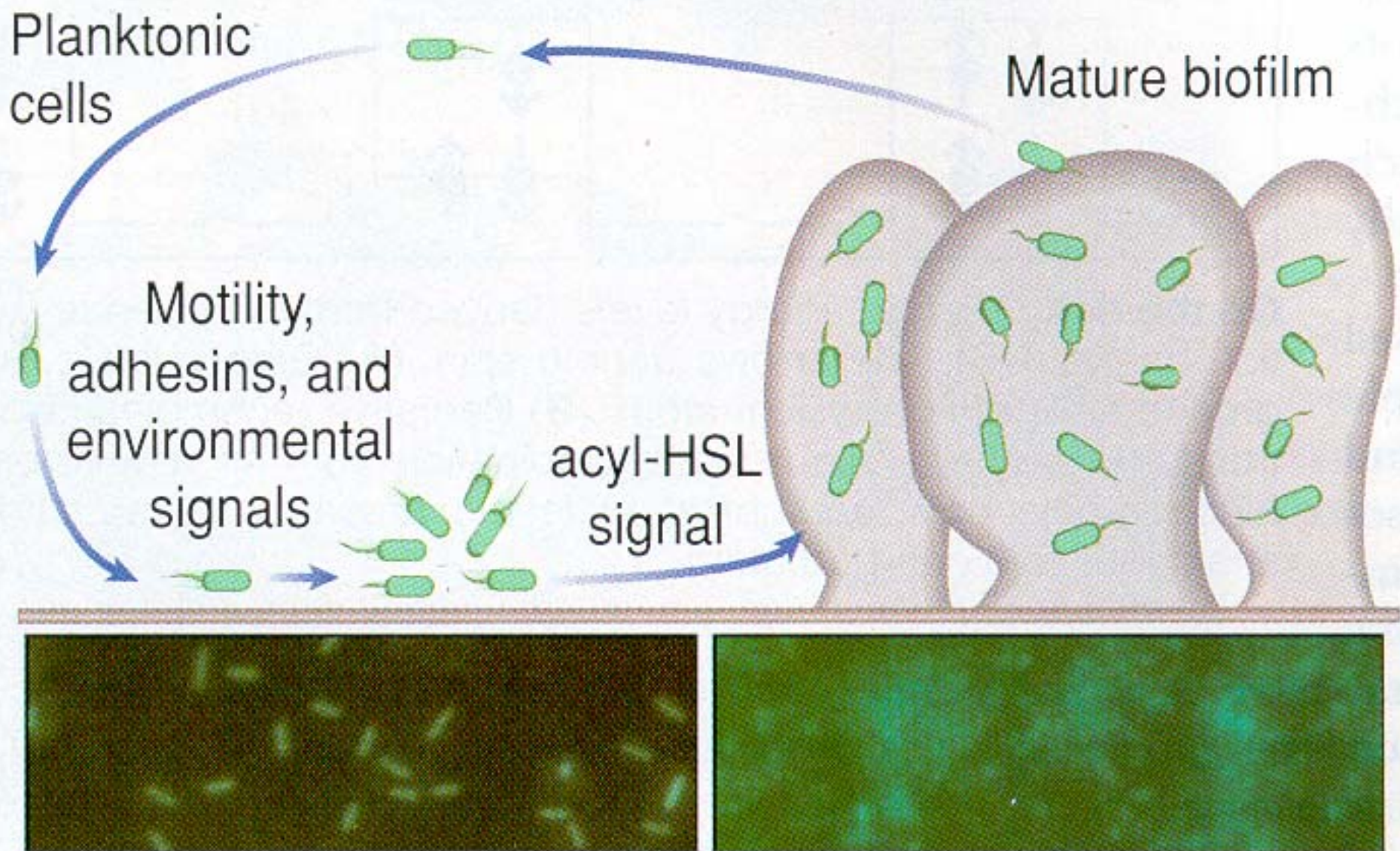

**Construction of a biofilm.** Free (planktonic) bacteria assemble on a surface (**left**). Cell-to-cell communication then induces the formation of multicellular pillars and columns (**right**).

Fluorescently tagged bacteria in a biofilm.  
Notice water channels and extracellular matrix  
(e.g. polysaccharide).

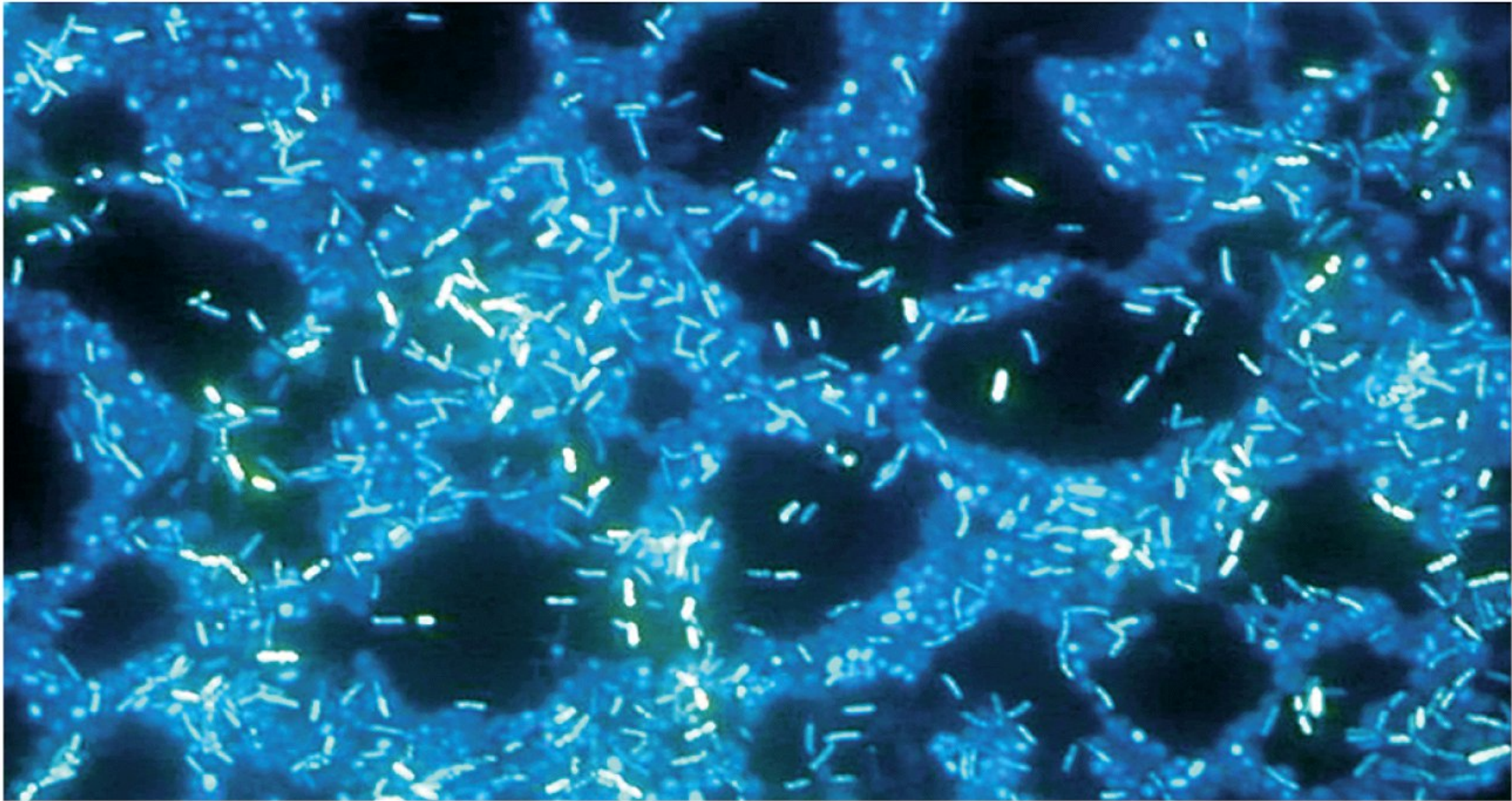

Rodney M. Donlan and Emerging Infectious Diseases

Figure 19-5b Brock Biology of Microorganisms 11/e  
© 2006 Pearson Prentice Hall, Inc.

You've never seen a biofilm before? Yes you have... the plaque on your teeth, the sludge in your bathroom sink drain, the slime on your shower curtain...

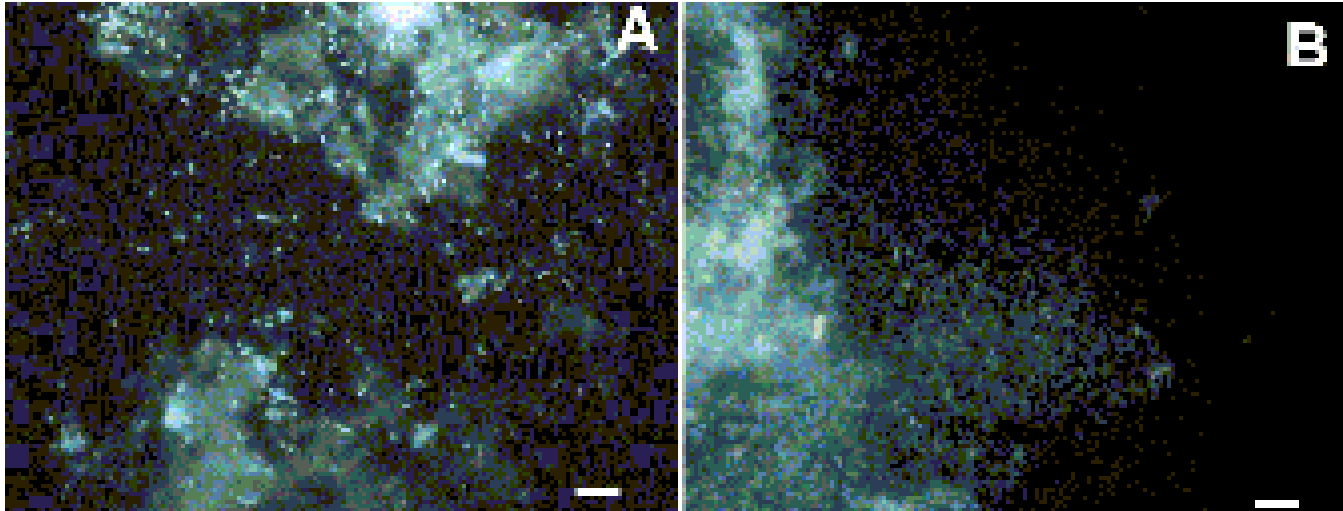

Epifluorescence microscopy of biofilm samples taken from shower curtains. These communities can contain diverse populations of microbes.

(Micrograph from Appl. Environ. Microbiol. 70:4187-4192.)

Cooperation among cells in a population: **myxobacteria**.

The myxobacteria are Gram-negative, ubiquitous, soil-dwelling bacteria that are capable of multicellular, social behaviour. In the presence of nutrients, "swarms" of myxobacteria feed cooperatively by sharing extracellular digestive enzymes, and can prey on other bacteria. When the food supply runs low, they initiate a complex developmental program that culminates in the production of a fruiting body composed of hundreds of thousands of cells. The myxobacteria communicate with each other, and coordinate their movements through a cell-contact-dependent signal.

--Adapted from Dale Kaiser, 2003. Nat. Rev. Microbiol. 1:45

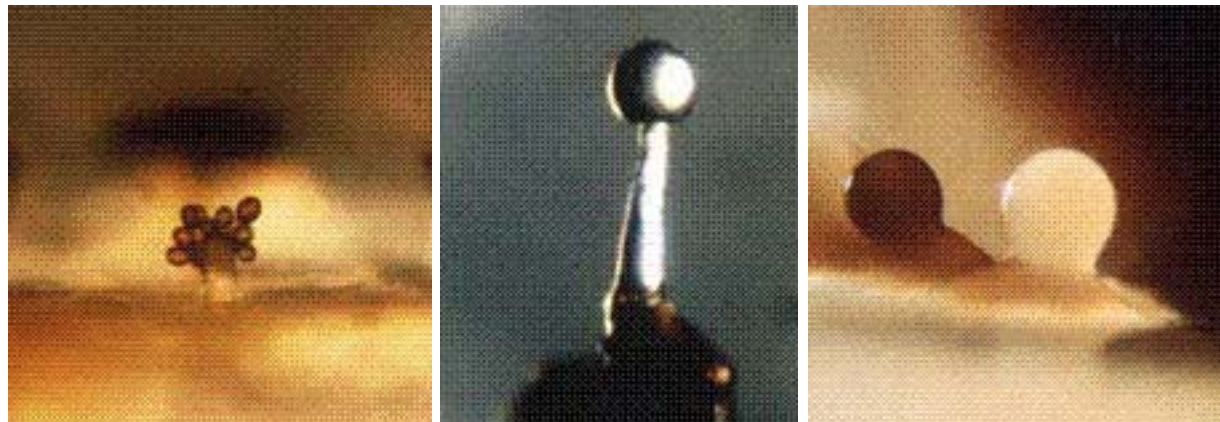

*Stigmatella aurantiaca*

*Myxococcus stipitatus*

*Stigmatella aurantiaca*

PHOTOS COURTESY OF HANS REICHENBACH

**Myxobacteria movie!**





## ***Myxococcus xanthus* signals starvation with diffusible A-factor, resulting in aggregation**

Cells sense that nutrient density is getting low, and release **A-factor**

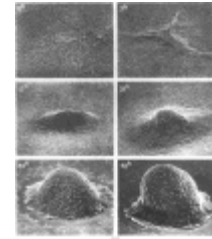

JM Kunder and D. Kaiser, 1982

### **A-factor**

- mix of 6 amino acids (result of proteolysis): trp, pro, phe, tyr, leu, ile
- amino acids are 10-fold less than concentration necessary to support growth
- only released by starving cells
- each cell only releases a fixed amount of A-factor
- A-factor is diffusible

If enough cells release A-factor, the population “agrees” to commit to fruiting body development, and begins the first stages of aggregation.

There’s a time limit for fruiting body formation. During starvation, cells “sense impending doom” and seem to act proactively to fruit and disperse. (Why?).

Cells sense actual starvation as the lack of one or more amino acylated tRNAs, which triggers the “stringent response” during which protein synthesis is temporarily shut down, so no fruiting body could be formed.

## ***Myxococcus xanthus* coordinates cell movement with C-factor, non-diffusible**

2. C-factor, another signal, helps organize the movement\* of cells:

rippling

aggregation

end-to-end packing in “rafts” inside spores.

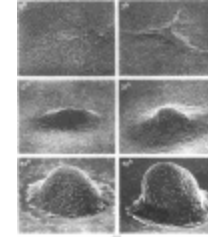

JM Kunder and D. Kaiser, 1982

C-factor is a small (20 kD), membrane-bound protein

C-factor is NOT diffusible.

C-factor requires cell-cell contact

C-factor autoinduces, and there are thresholds of C-factor for each subsequent developmental stage

\*Gliding motility in *M. xanthus* involves two different “gliding machines”, one at each cell pole:

1. the S-machine, which depends on type IV pili

2. the A-machine, which seems to involve a slime extrusion mechanism.

C-signal induces cells to move with increased gliding speeds, in longer gliding intervals and with decreased stop and reversal frequencies... increasing travel rates of cells.

## Microbes are useful for studying ecological interactions and evolution...

Myxobacteria share characteristics of uni- and multi-cellular organisms. They grow and divide as do all Gram-negative bacteria. In abundant nutrients, they don't form fruiting bodies.

*In vitro* natural selection: grew 12 "lines" of *Myxococcus* in test tube without starving, for 1000 generations. More than half of these developed mutants that lost fruiting body development and sporulation efficiency. (Velicer, Kroos, **Lenski**, 1998. PNAS 95: 12376)

Why is social behavior selected for, in the wild (in the soil)?

1. Spore is bigger than a cell: 0.2 mm in diameter. Can adhere to passing animal (e.g. worm, mite) and be carried to new food source.
2. Wolf pack feeding: once spores germinate in new spot, the cells secrete extracellular enzymes *en masse*, thus degrading food much more efficiently

# Soil Heterogeneity

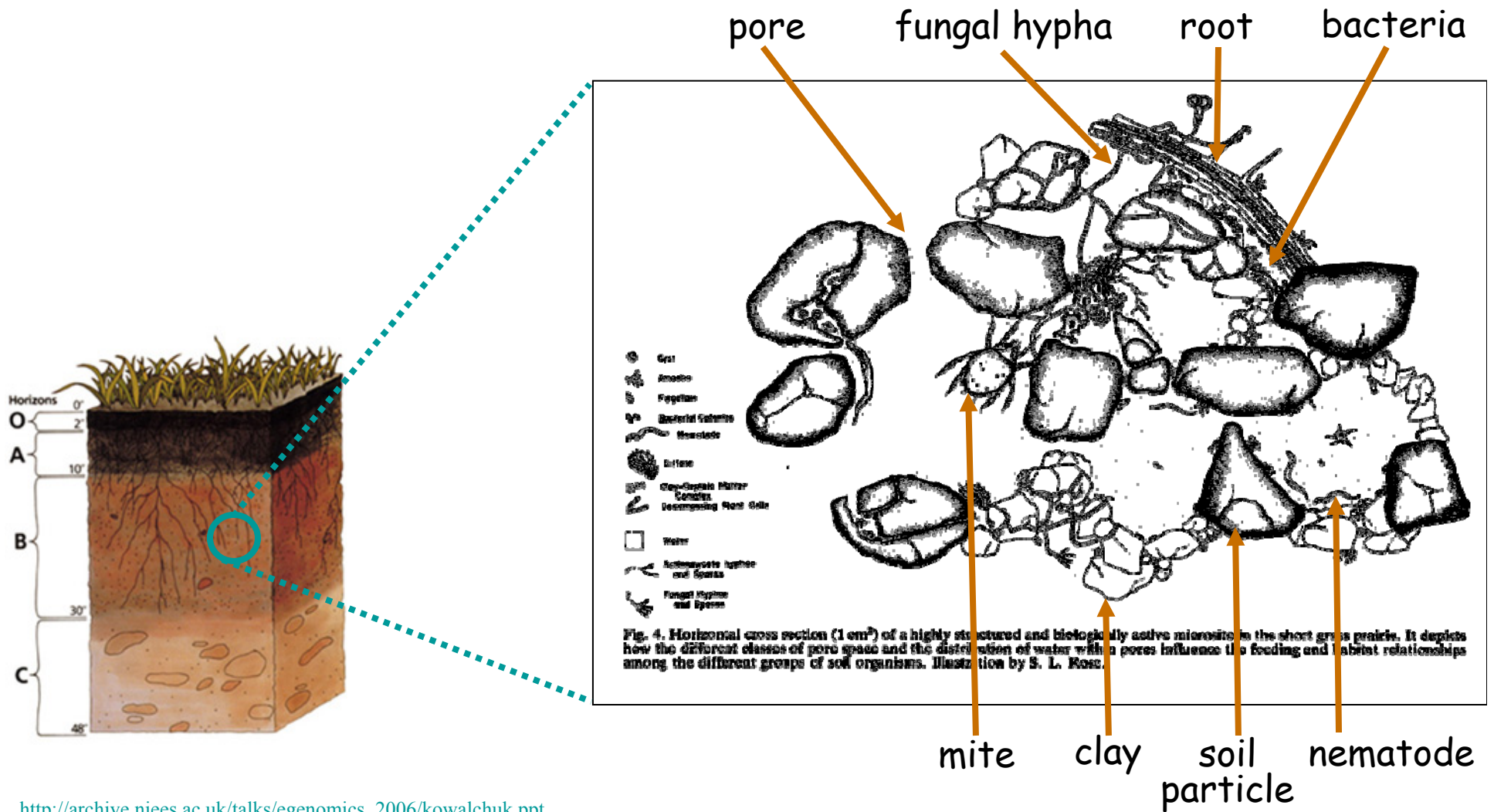

# Are soil-borne microbes living on islands?

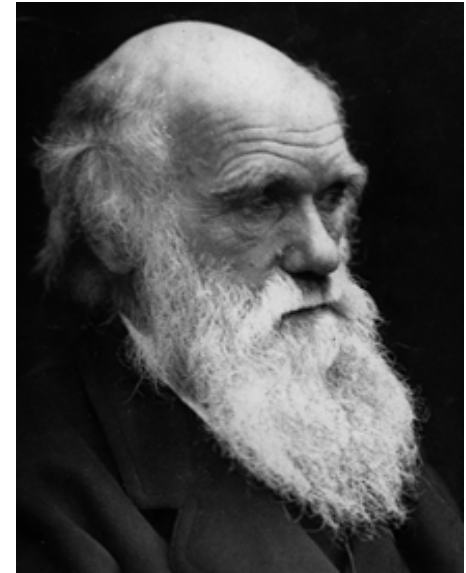
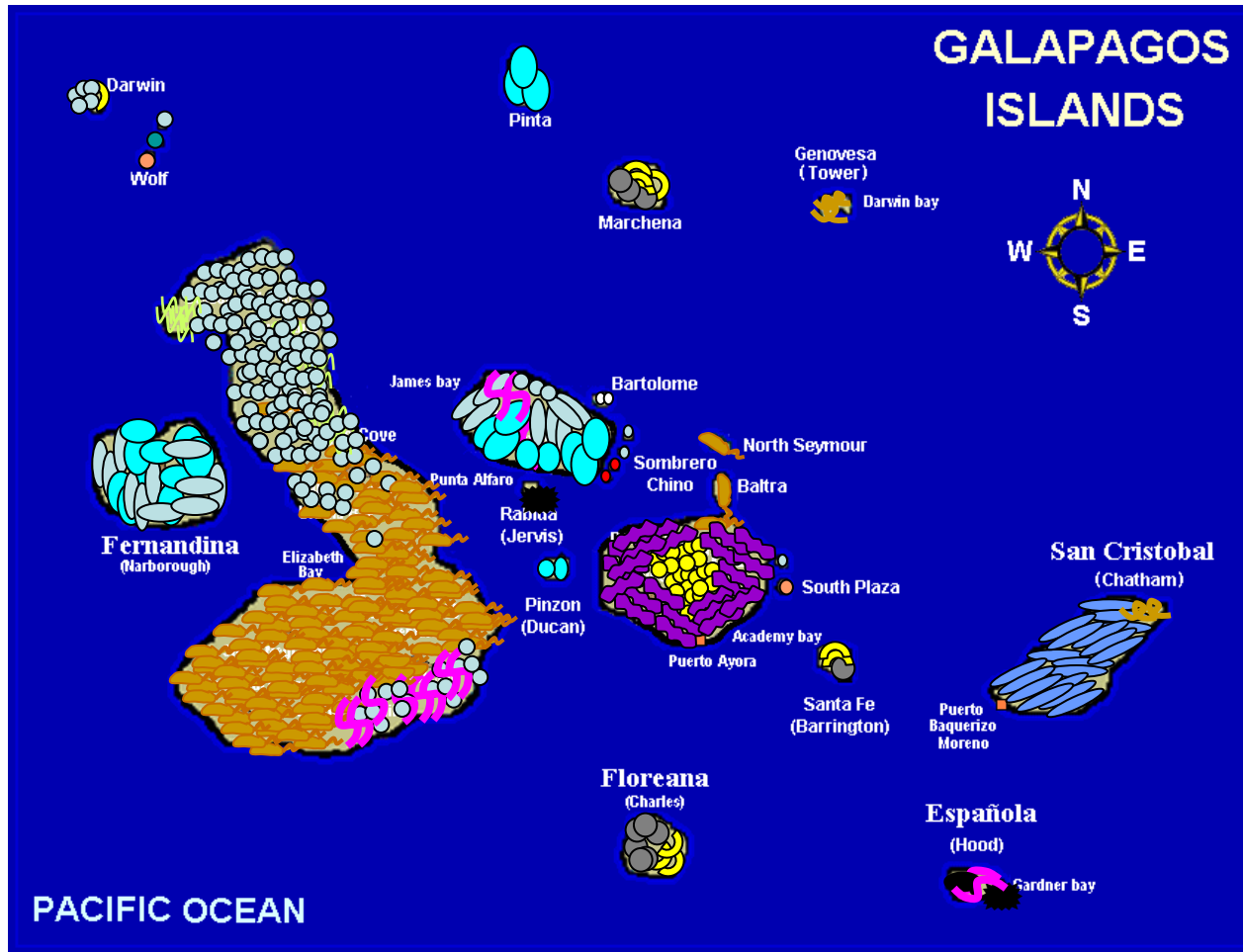

# State of the art: metagenomics to determine identity and (potential) functions of soil bacteria

- Identify dominant microbial populations in the rhizosphere that cannot yet be cultured
- Construct large-insert metagenomic libraries from rhizosphere soil
- Begin investigating the genomic potential of dominant rhizosphere bacteria
- Detect novel microbial activities

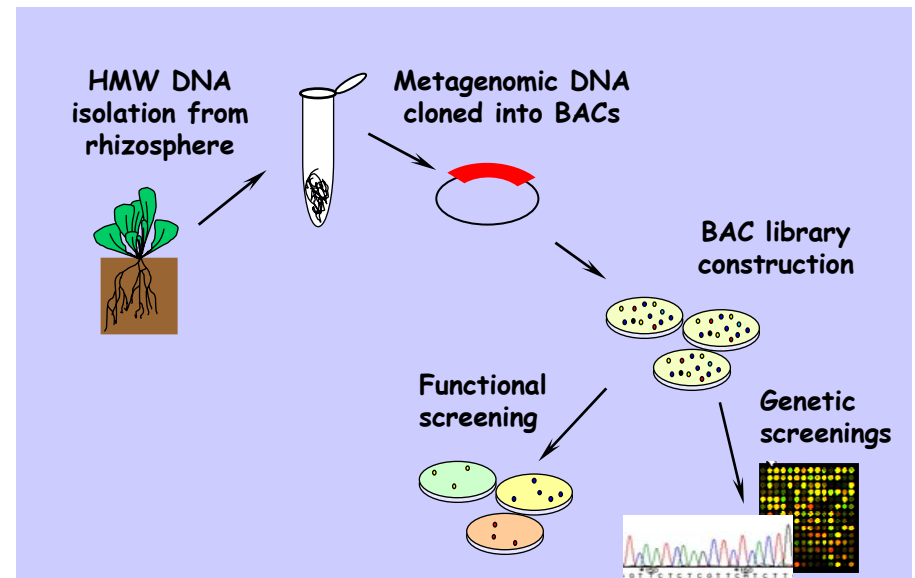

# Good web sites:

Microbe Magazine:

<http://www.asm.org/microbe/>

International Society for Microbial Ecology:

<http://www.isme-microbes.org/>

Micobe Zoo:

<http://commtechlab.msu.edu/sites/dlc-me/zoo/index.html>

Microbe World:

<http://www.microbeworld.org/>

Kenneth Todar's Online Textbook of Bacteriology:

<http://www.textbookofbacteriology.net/>

Small Things Considered:

<http://schaechter.asmblog.org/schaechter/>

Dimensions of Microbiology:

<http://www.centres.ex.ac.uk/egenis/microbiology/index.htm>

Dr. Moyer's research:

<http://earthref.org/FEMO/cruises/2007/index.html>

Departmental Seminar  
Wednesday, April 2  
4 p.m.

Dr. Reid Harris, James Madison University, VA

Microbial ecology of amphibian skin and mechanisms  
of disease prevention by mutualistic bacteria



# Formation of the endospore

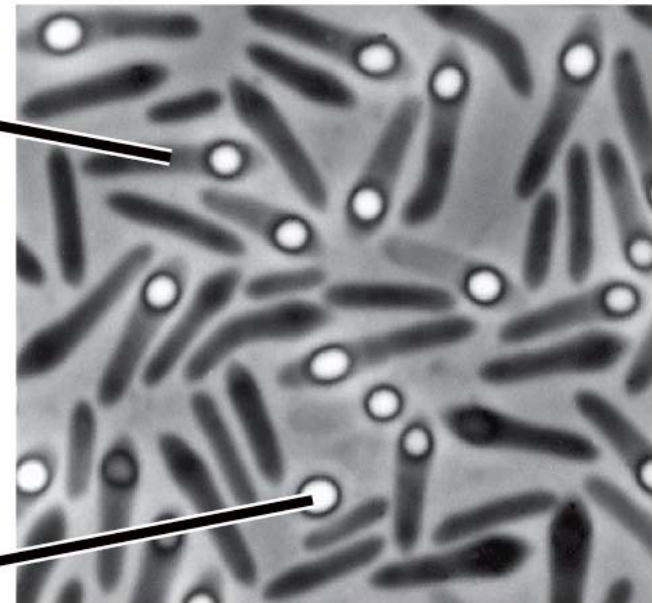
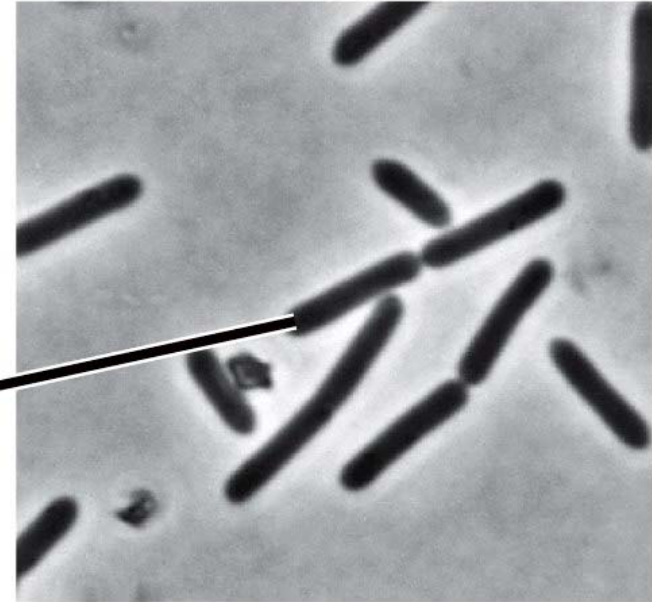
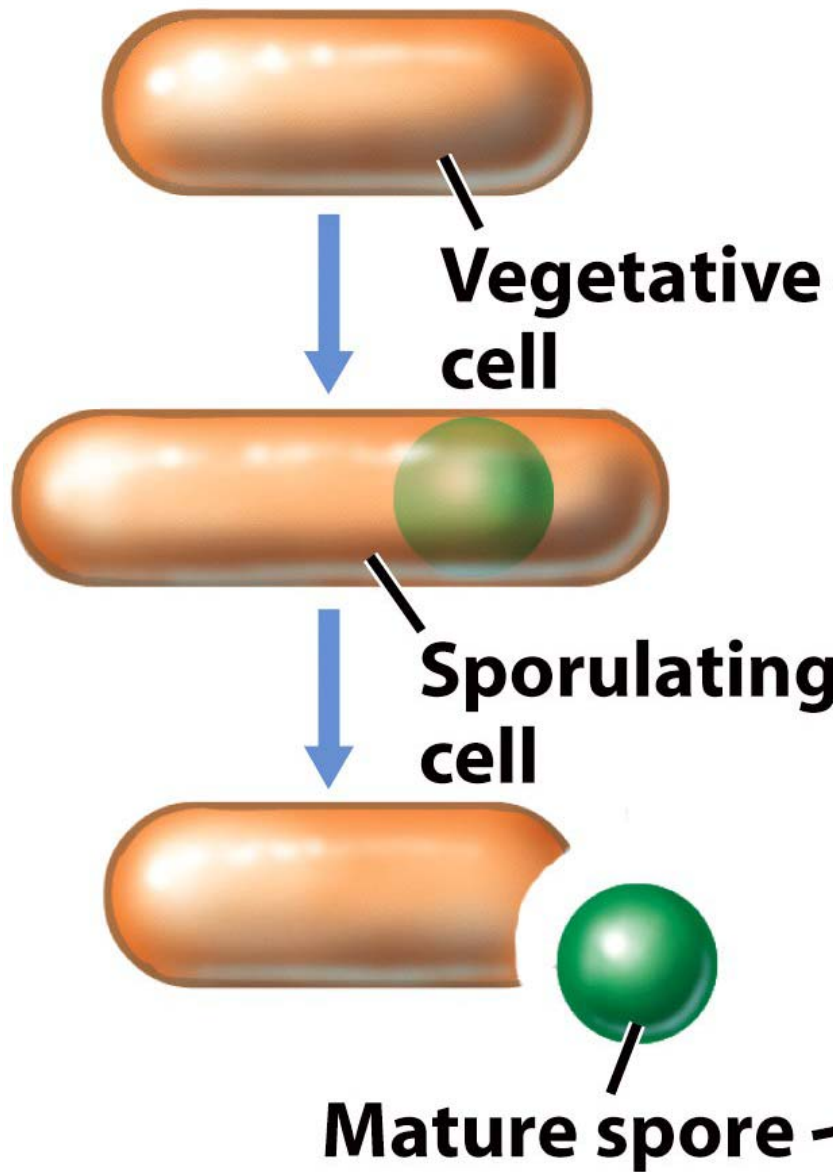

## Bacterial Capsules:

(a) *Acinetobacter* sp.

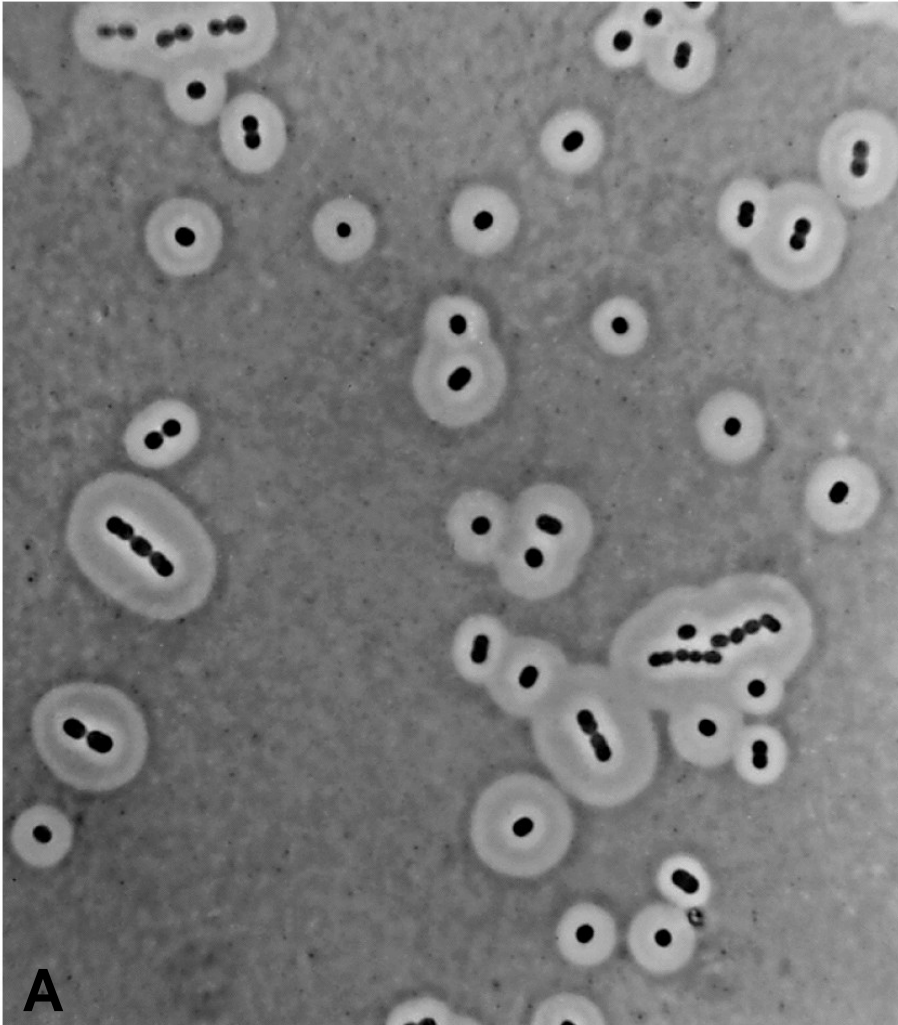

(b) *Rhizobium trifolii*

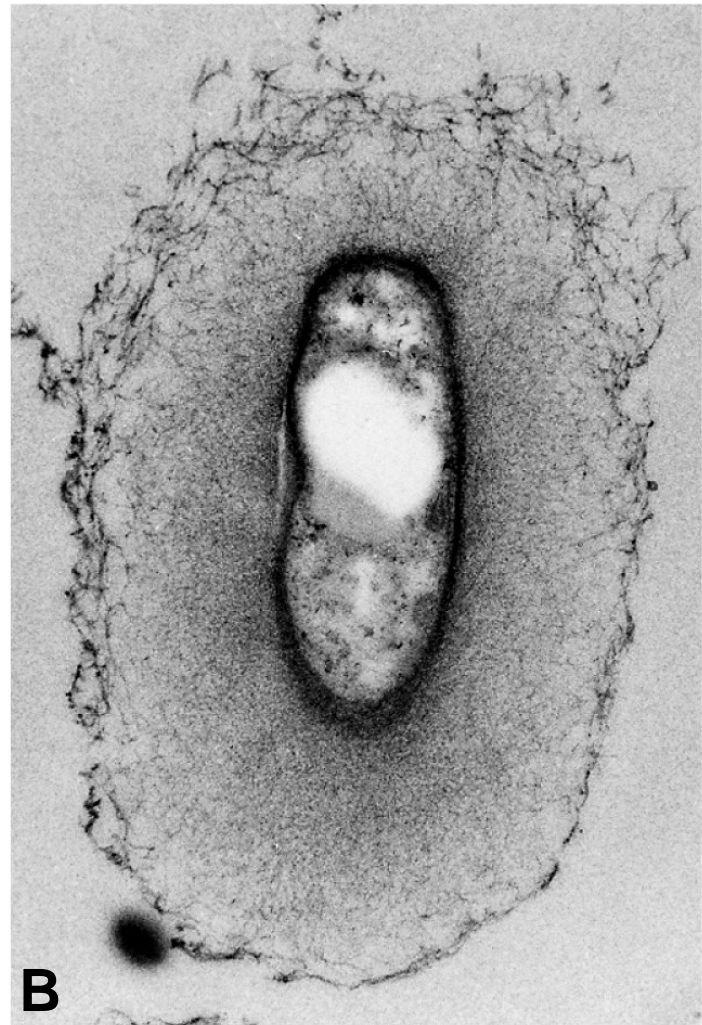

negative stain

# Flagella



• **Monotrichous**

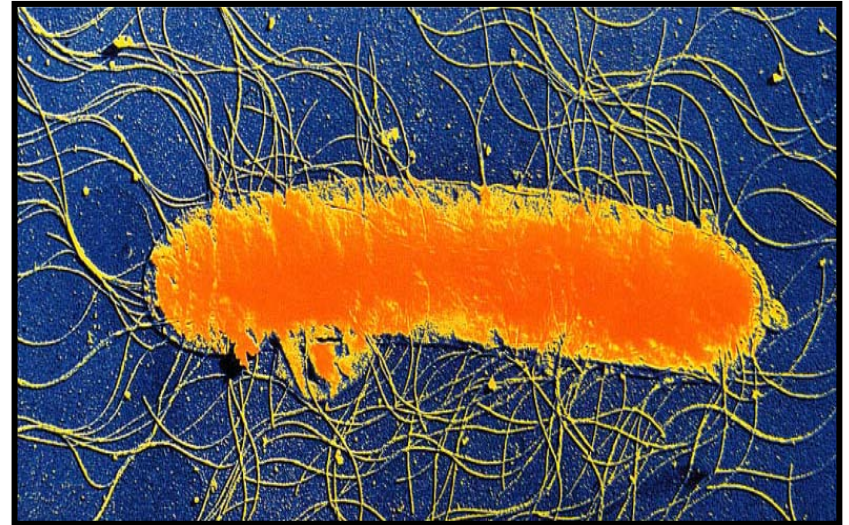

• **Peritrichous**



• **Amphitrichous**

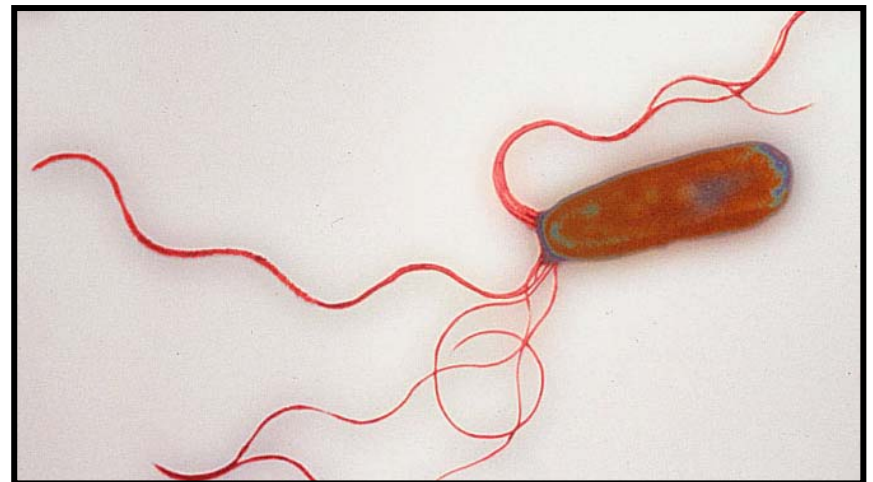

• **Lophotrichous**

# Fimbriae

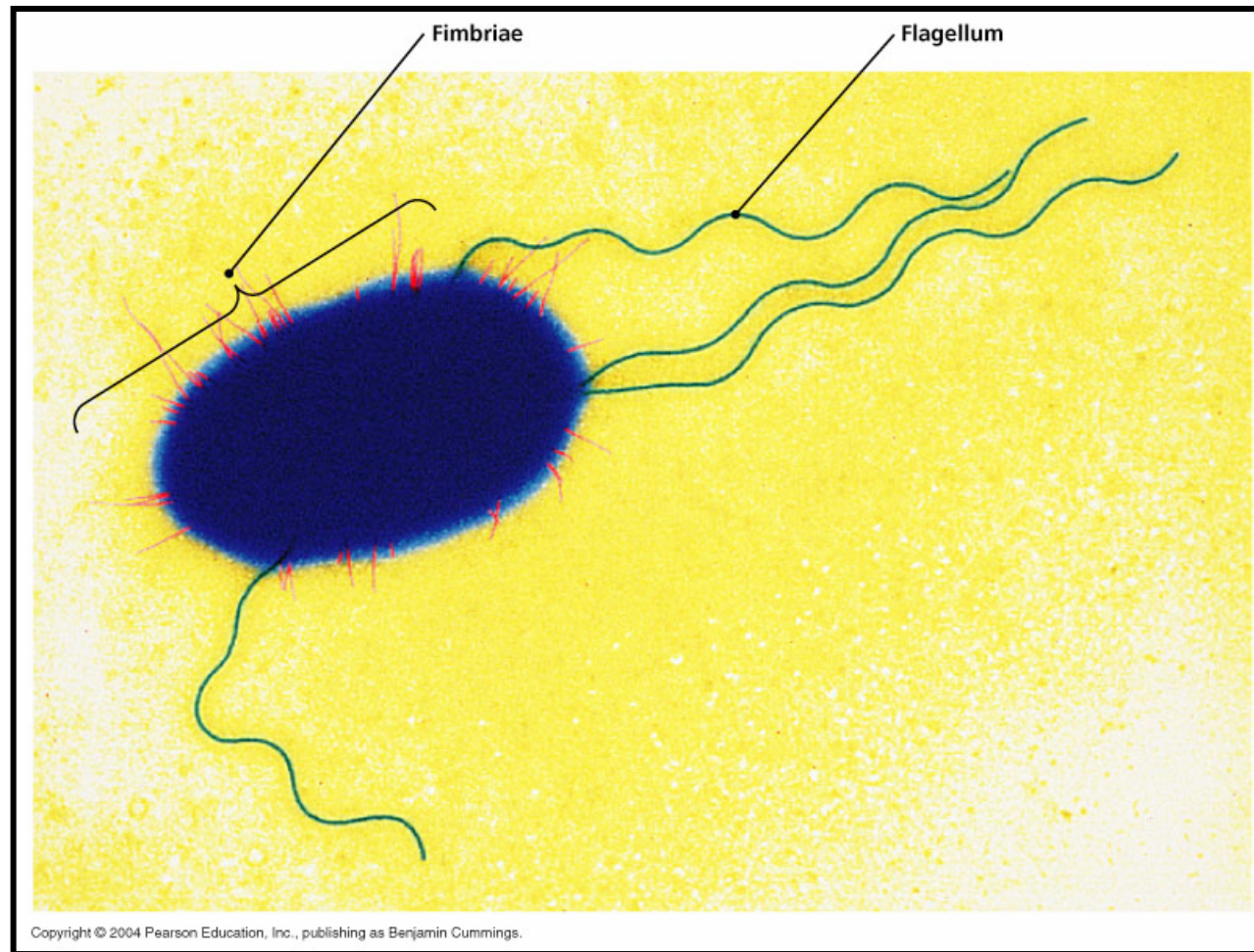

*E. coli*

- Uropathogenic *E. coli* use fimbriae to adhere to urinary tract
- Hold 'tighter' in high flow, release and swim in low flow
- Critical pathogenicity factor

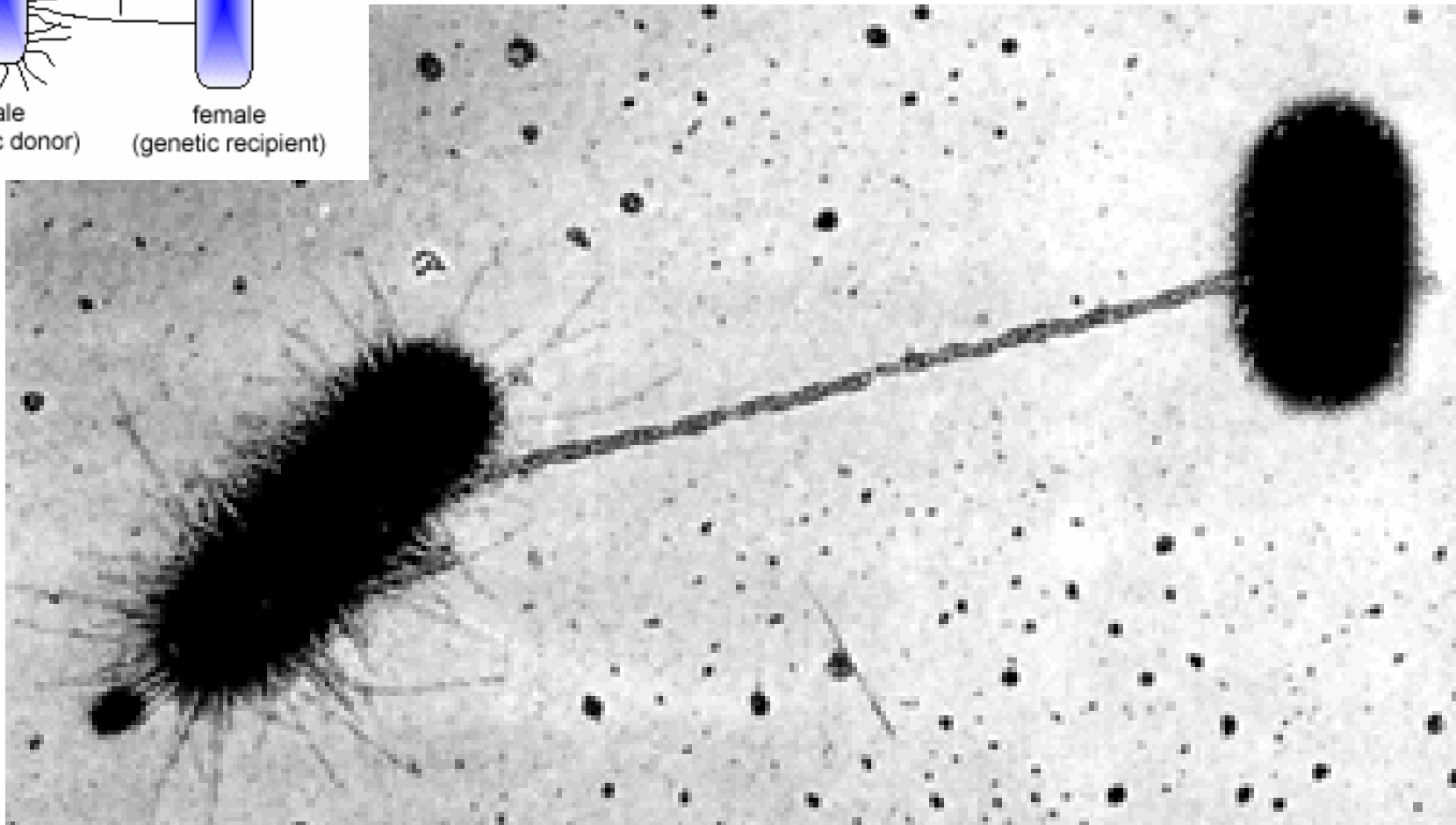
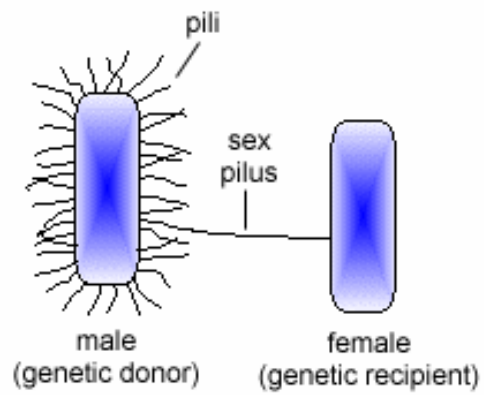

“Sex” Pili used in bacterial conjugation of *E. coli* cells



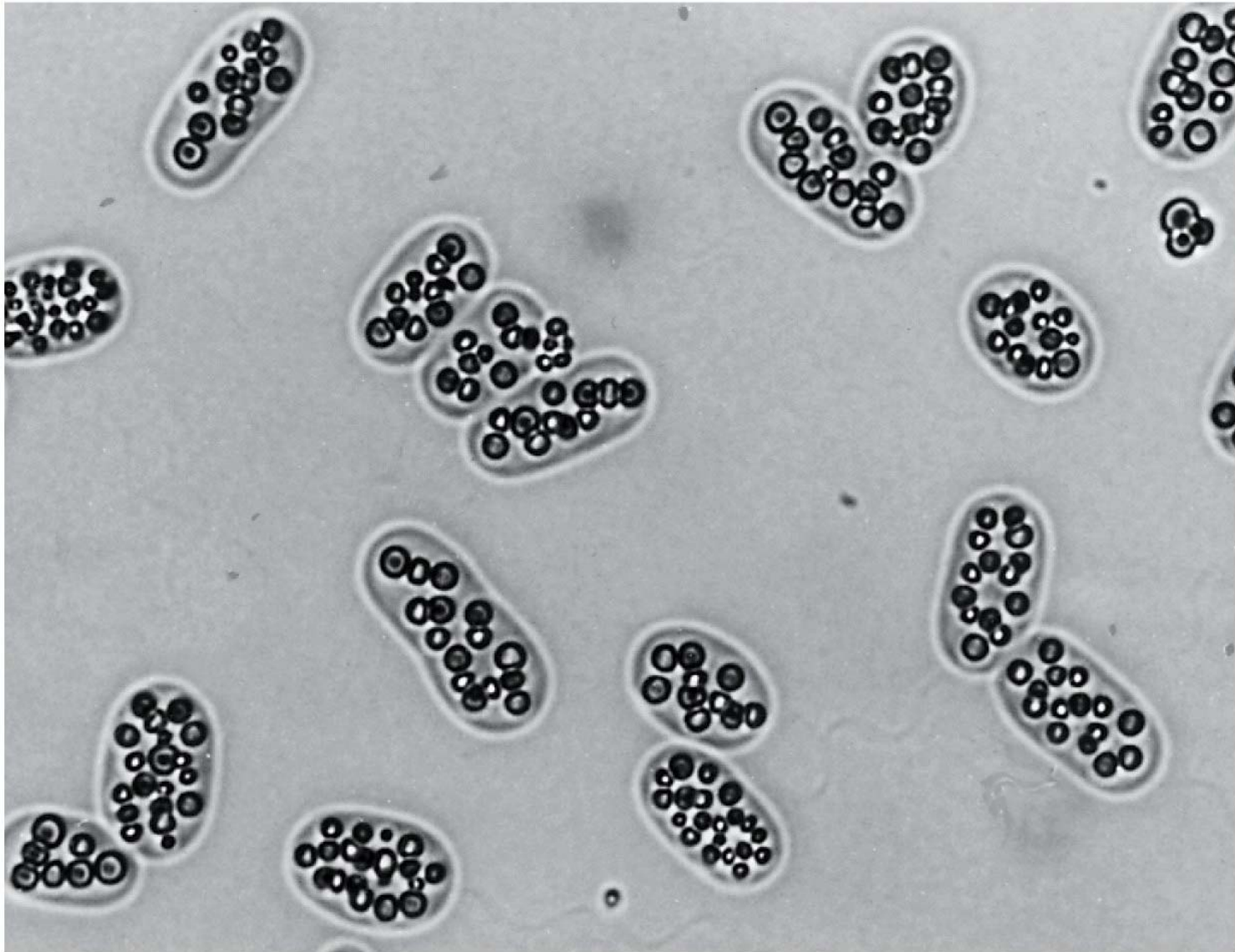

Sulfur globules inside the purple sulfur bacterium *Isochromatium buderi*: oxidation of  $\text{H}_2\text{S}$

Magnetotactic bacteria with  $\text{Fe}_3\text{O}_4$  (magnetite) particles called **magnetosomes** – function unknown

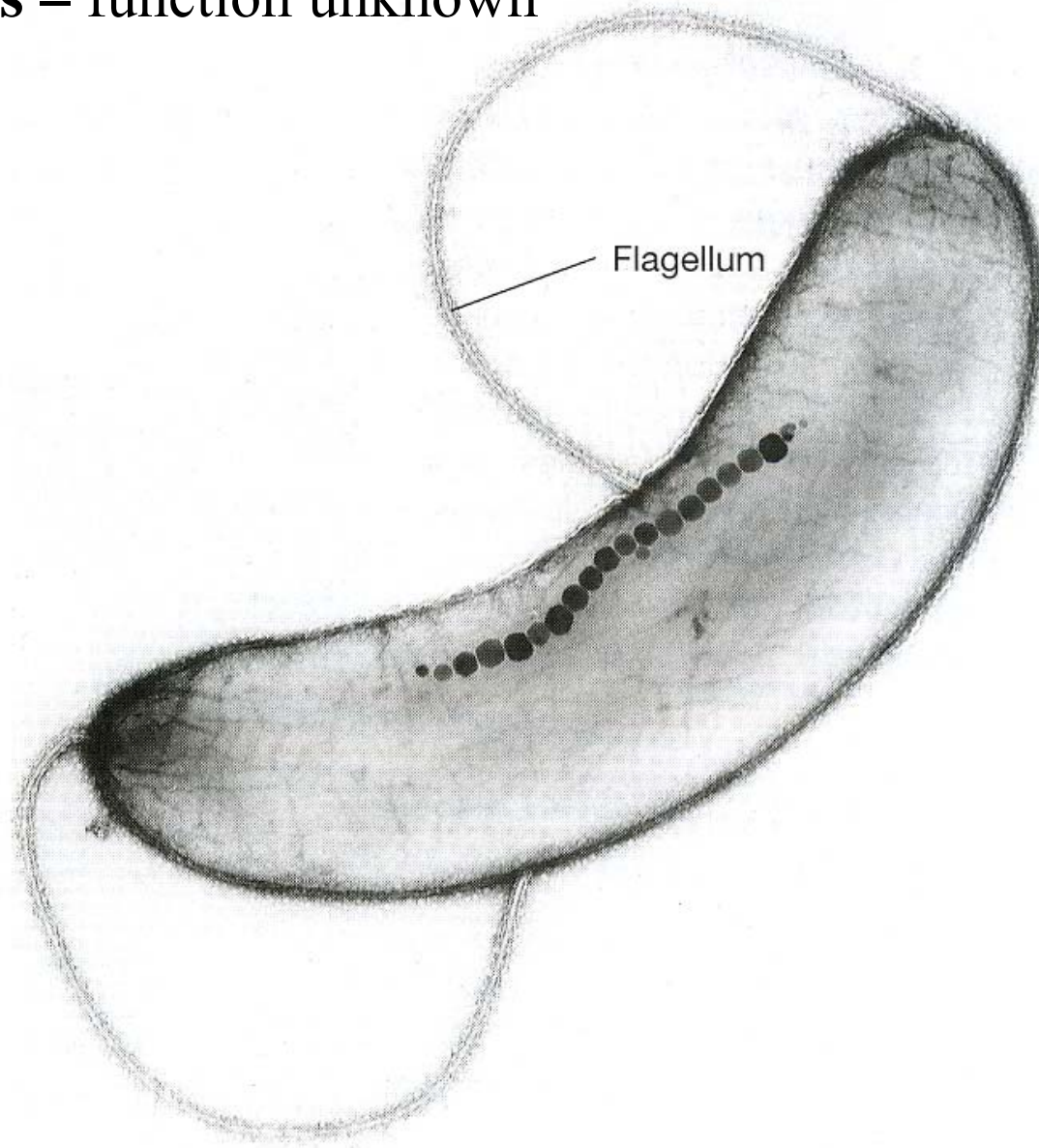



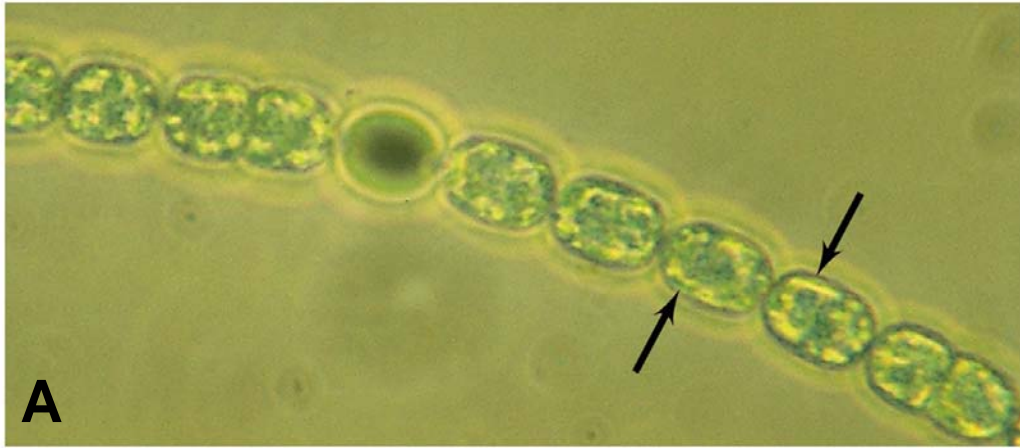

## Gas Vesicles

(a) *Anabaena flos-aquae*

(b) *Microcystis* sp.

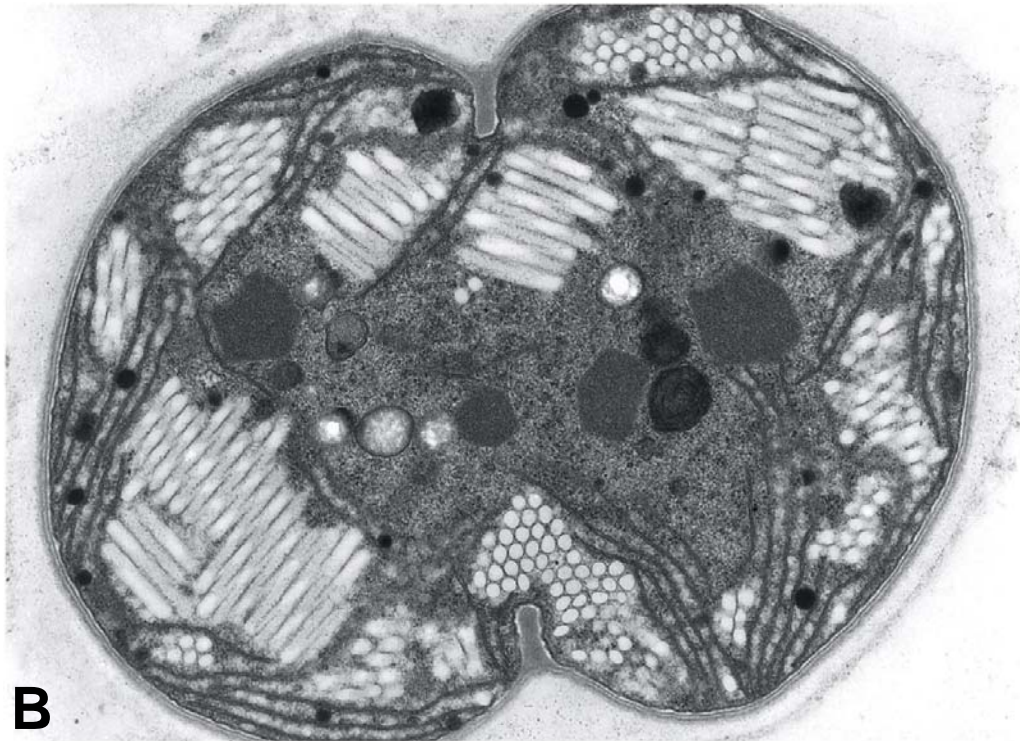

## What about the ecology of human microbes?

[http://www.sciencemag.org.offcampus.lib.washington.edu/cgi/content/full/288/5464/287?ijkey=24bb1901e27ef8c3c0a1caeb6246bf2f9a4f6776&keytype=tf\\_ipsecsha](http://www.sciencemag.org.offcampus.lib.washington.edu/cgi/content/full/288/5464/287?ijkey=24bb1901e27ef8c3c0a1caeb6246bf2f9a4f6776&keytype=tf_ipsecsha)

<http://www.pnas.org.offcampus.lib.washington.edu/cgi/content/full/105/6/2117>

<http://jn.nutrition.org.offcampus.lib.washington.edu/cgi/reprint/134/2/459>

<http://www.nature.com.offcampus.lib.washington.edu/nrmicro/journal/v3/n5/abs/nrmicro1152.html>

<http://www.nature.com.offcampus.lib.washington.edu/nm/journal/v12/n7/abs/nm0706-736.html>

<http://www.nature.com.offcampus.lib.washington.edu/nature/journal/v444/n7122/abs/nature05414.html>

- Big questions, small worlds: microbial model systems in ecology
- **Christine M. Jessup**, **1**, **Rees Kassen****2**, **Samantha E. Forde****1**, **Ben Kerr****3**, **Angus Buckling****4**, **Paul B. Rainey****5**, **6** and **Brendan J. M. Bohannan****1**  
**Trends in Ecology & Evolution**  
**Volume 19, Issue 4, April 2004, Pages 189-197**
- <http://www.agron.iastate.edu/~loynachan/mov/>