

Lecture Series 6  
DNA and Its Role in Heredity

---

---

---

---

---

---

---

---

Reading Assignments

- Read Chapter 5  
DNA and Chromosomes
- Read Chapter 6  
DNA Replication, Repair & Recombination  
(skim pages 215 to 222 on Recombination)
- Read Chapter 10  
Pages 331 to 333 and 347 to 351  
(only sections on Sequencing and PCR)

---

---

---

---

---

---

---

---

A. DNA: The Genetic Material

- In addition to circumstantial evidence, two key experiments demonstrated that DNA is the genetic material.
- In the first key experiment (Griffiths, 1928) showed that a virulent strain of *Streptococcus pneumoniae* genetically transformed nonvirulent *S. pneumoniae* into virulent bacteria.

---

---

---

---

---

---

---

---

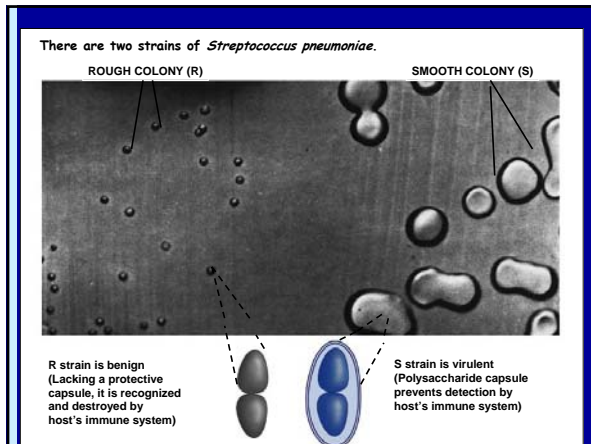

---

---

---

---

---

---

---

---

---

---

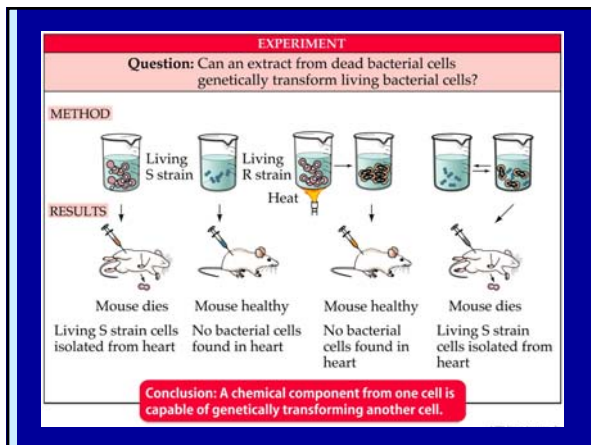

---

---

---

---

---

---

---

---

---

---

## A. DNA: The Genetic Material

- In a prelude to the second key experiment (Avery, 1944) showed that DNA was the transforming agent through studies of T-even bacteriophage and their treatment with hydrolytic enzymes.
- The second key experiment (Hershey & Chase, 1952) showed that labeled viruses were incubated with host bacteria. Labeled viral DNA entered host cells, producing many label-bearing viruses.

---

---

---

---

---

---

---

---

---

---

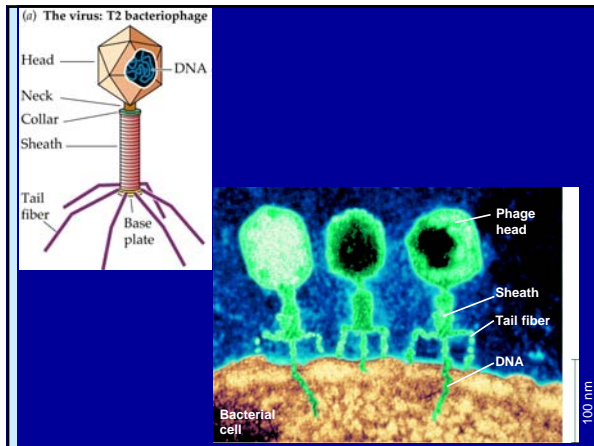

---

---

---

---

---

---

---

---

---

---

---

---

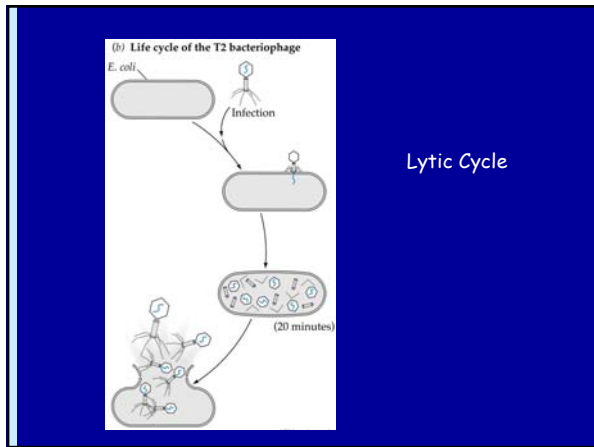

---

---

---

---

---

---

---

---

---

---

---

---

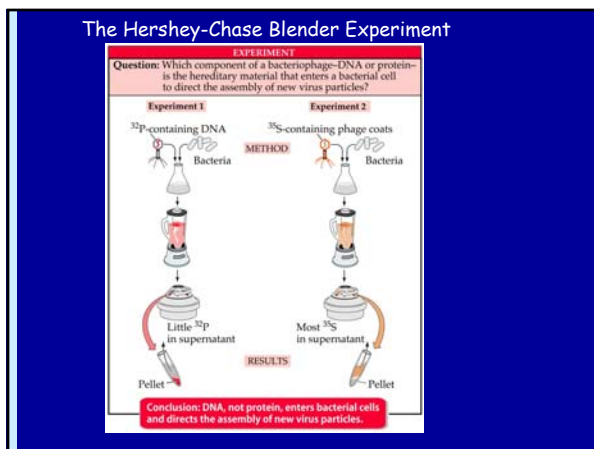

---

---

---

---

---

---

---

---

---

---

---

---

## B. The Structure of DNA

- X-ray crystallography showed that the DNA molecule is a helix.

---

---

---

---

---

---

---

---

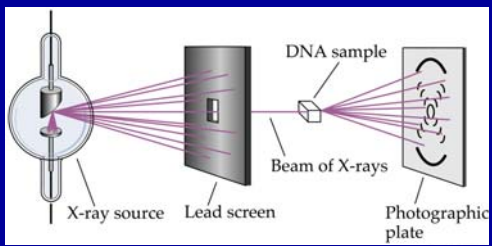

---

---

---

---

---

---

---

---

Rosalind Franklin and her X-ray diffraction photo of DNA

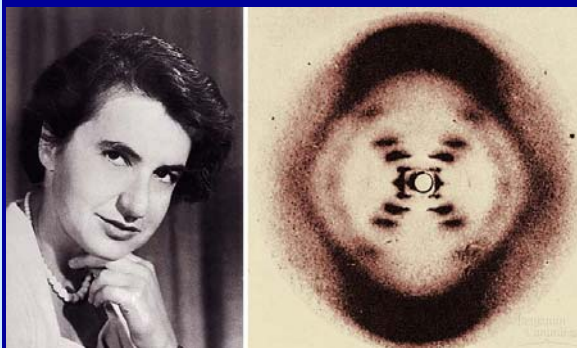

---

---

---

---

---

---

---

---

## B. The Structure of DNA

- DNA is composed of nucleotides, each containing adenine, cytosine, thymine, or guanine.
- There are equal amounts of adenine and thymine and equal amounts of guanine and cytosine. This is known as *Chargaff's Rule* (1950, using paper TLC).

---

---

---

---

---

---

---

---

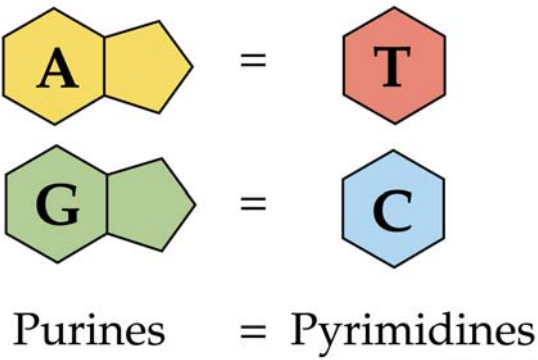

---

---

---

---

---

---

---

---

## B. The Structure of DNA

- Watson and Crick (1953) proposed that DNA is a double-stranded helix with antiparallel strands, and with bases linked by hydrogen bonding.
- Their model accounts for genetic information, mutation, and replication functions of DNA.

---

---

---

---

---

---

---

---

### The Double Helix

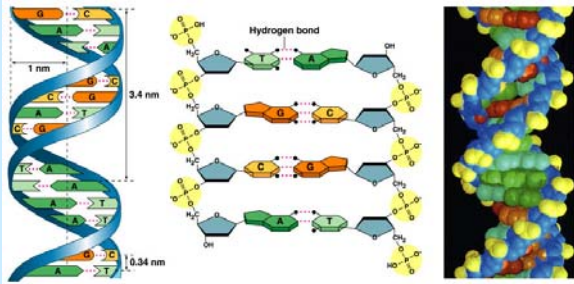

---

---

---

---

---

---

---

---

### Purine and Pyrimidine Fit

**Purine + purine: too wide**

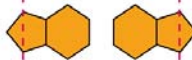

**Pyrimidine + pyrimidine: too narrow**



**Purine + pyrimidine: width consistent with X-ray data**



---

---

---

---

---

---

---

---

### Watson and Crick and their Model



---

---

---

---

---

---

---

---

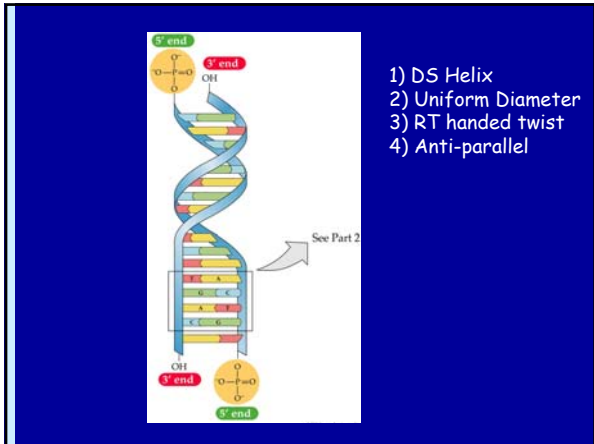

- 1) DS Helix
- 2) Uniform Diameter
- 3) RT handed twist
- 4) Anti-parallel

---

---

---

---

---

---

---

---

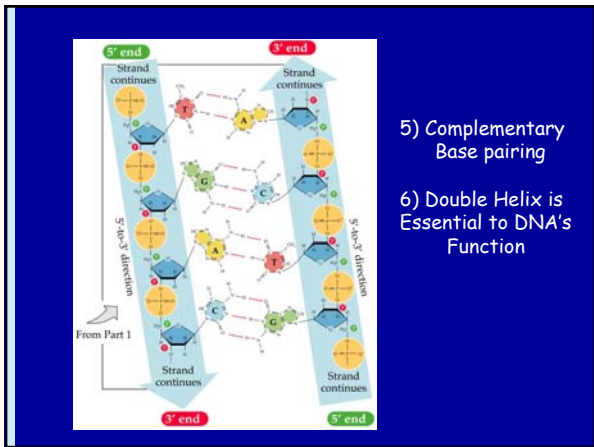

- 5) Complementary Base pairing
- 6) Double Helix is Essential to DNA's Function

---

---

---

---

---

---

---

---

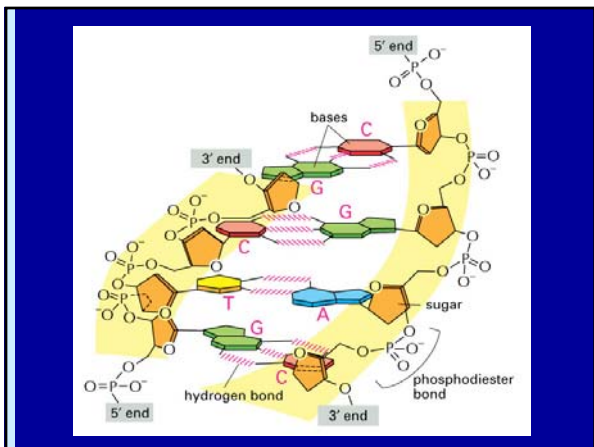

---

---

---

---

---

---

---

---

## C. DNA Replication

- Semiconservative, conservative, and dispersive models for DNA replication were hypothesized.
- Each obeyed base-pairing rules.

---

---

---

---

---

---

---

---

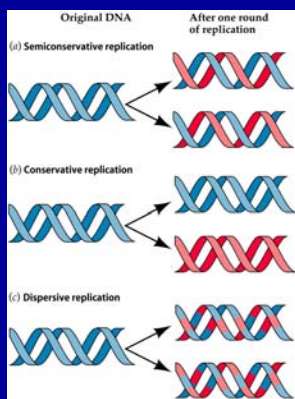

---

---

---

---

---

---

---

---

## C. DNA Replication

- Kornberg (1956) demonstrated *in vitro* that DNA served as its own template during replication.
- Meselson and Stahl's experiment (1957) proved replication of DNA to be semiconservative. A parent strand is a template for synthesis of a new strand. Two replicated DNA helices contain one parent strand and one synthesized strand each.

---

---

---

---

---

---

---

---



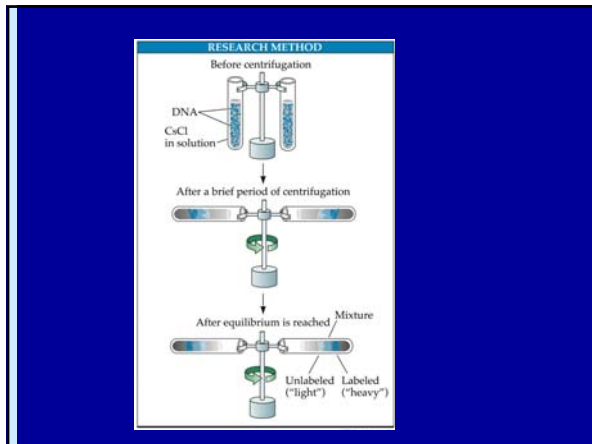

---

---

---

---

---

---

---

---

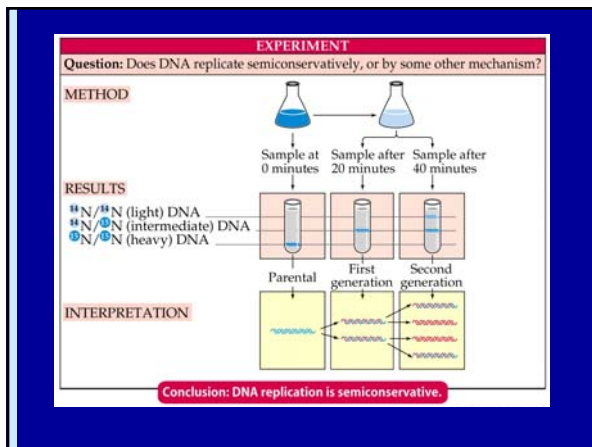

---

---

---

---

---

---

---

---

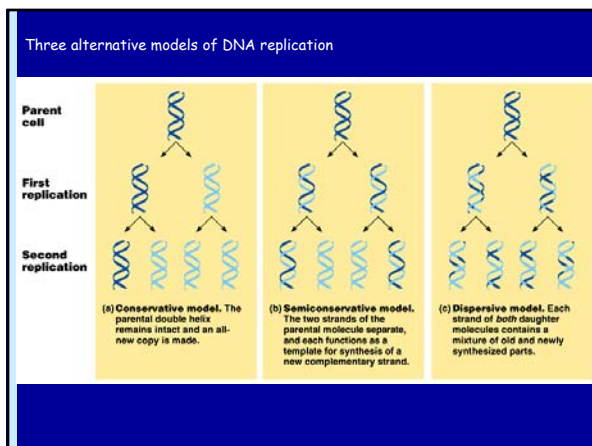

---

---

---

---

---

---

---

---

## D. The Mechanism of DNA Replication

- DNA polymerase catalyzes nucleotides from the 5' to the 3' end.
- Nucleotides are added by complementary base pairing with the template strand.
- The substrates, deoxyribonucleoside triphosphates, are hydrolyzed as added, releasing energy for DNA synthesis.

---

---

---

---

---

---

---

---

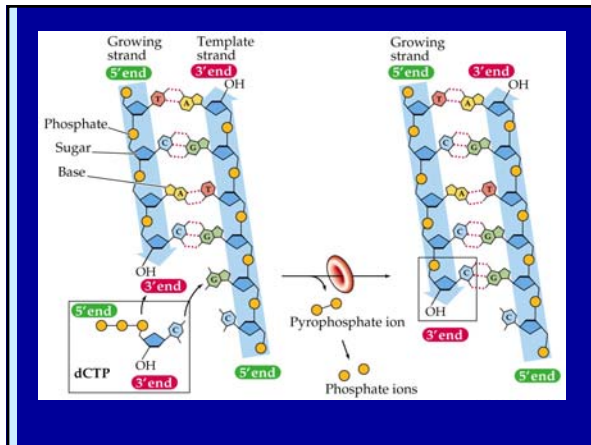

---

---

---

---

---

---

---

---

## D. The Mechanism of DNA Replication

- News Flash: The DNA replication complex is in a fixed location and DNA is threaded through it for replication.
- Old idea was via moving replication forks.

---

---

---

---

---

---

---

---

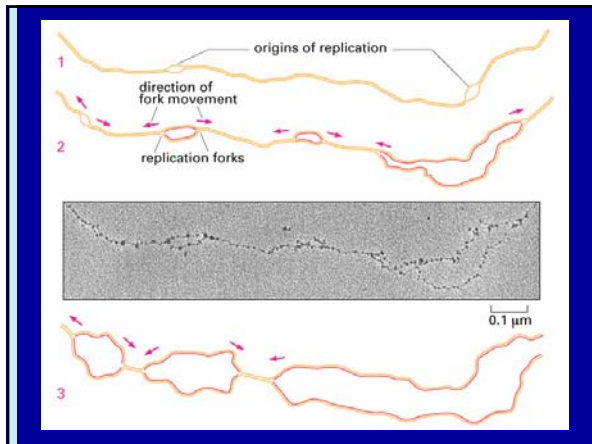

---

---

---

---

---

---

---

---

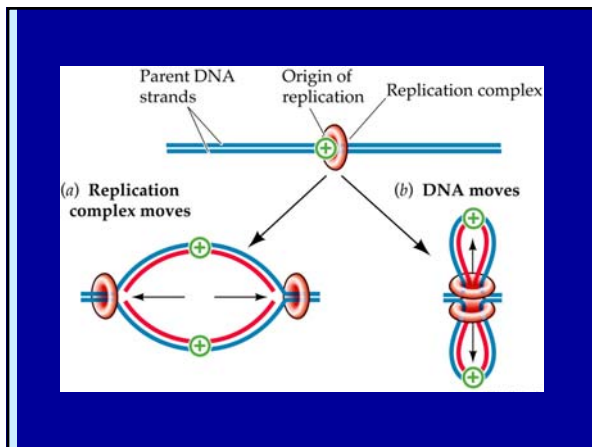

---

---

---

---

---

---

---

---

## D. The Mechanism of DNA Replication

- Prokaryotes have a single origin of replication; eukaryotes have many ( $10^2$  to  $10^3$ ).
- Replication for each proceeds in both directions from an origin of replication.

---

---

---

---

---

---

---

---

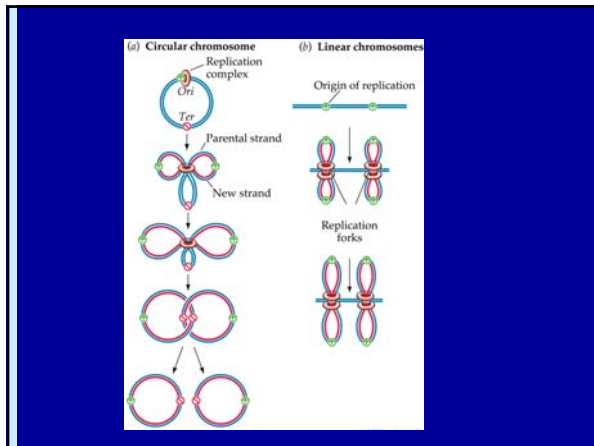

---

---

---

---

---

---

---

---

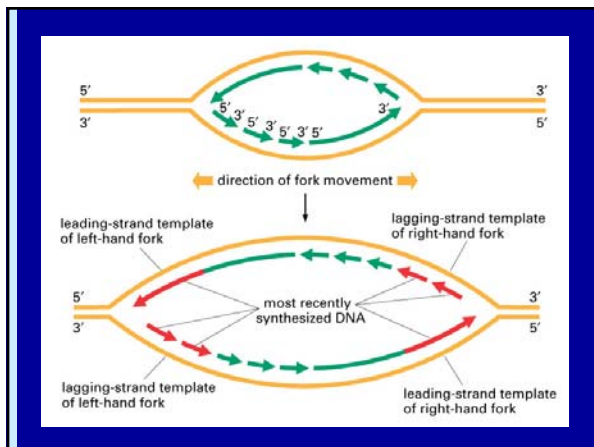

---

---

---

---

---

---

---

---

## D. The Mechanism of DNA Replication

- Many proteins assist in DNA replication. DNA helicases unwind the double helix, the template strands are stabilized by single-stranded binding proteins.
- An RNA primase catalyzes the synthesis of short RNA primers, and to which nucleotides are added.

---

---

---

---

---

---

---

---

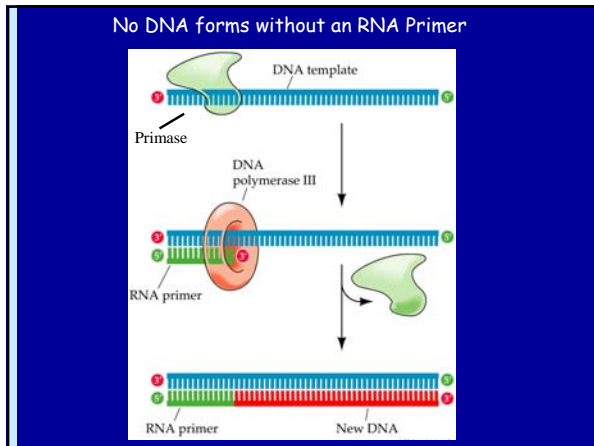

---

---

---

---

---

---

---

---

### D. The Mechanism of DNA Replication

- DNA polymerase III action causes the leading strand to grow in the 5'-to-3' direction until replication of that section of DNA is complete.
- RNA primer is degraded and DNA is replaced by DNA polymerase I.

---

---

---

---

---

---

---

---

### D. The Mechanism of DNA Replication

- On the lagging strand, growing in the other direction, DNA is made in the 5'-to-3' direction but synthesis is discontinuous: DNA is added as short Okazaki fragments to primers, then DNA polymerase III skips past the 5' end to make the next fragment.
- DNA polymerase I and Ligase are required to make lagging strand "continuous".

---

---

---

---

---

---

---

---

Many Proteins Collaborate at the Replication Fork

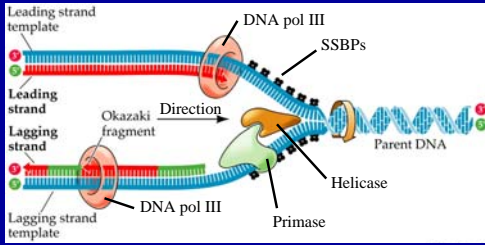

---

---

---

---

---

---

---

---

Two Daughter Strands form Different Ways

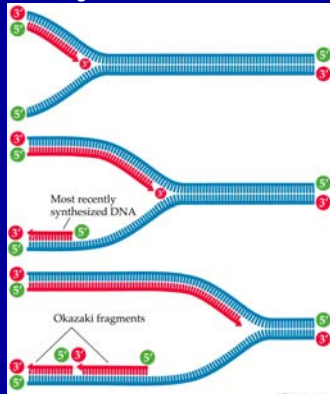

Continuous vs. Discontinuous!

---

---

---

---

---

---

---

---

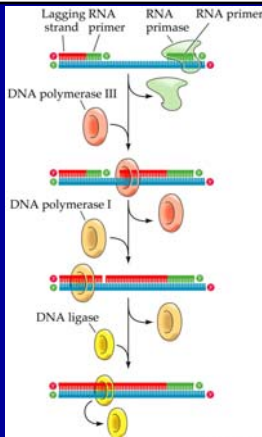

Finishing touches on the discontinuous or lagging strand

---

---

---

---

---

---

---

---

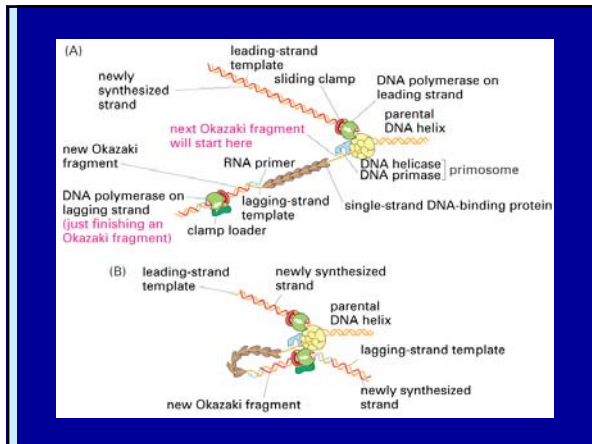

---

---

---

---

---

---

---

---

---

---

The main proteins of DNA replication and their functions

Initiation of replication

Double helix unwinds, providing single-stranded DNA templates      **Helicases and single-strand binding proteins**

	Synthesis of leading strand	Synthesis of lagging strand
Priming	<b>Primase</b>	Priming for Okazaki fragment <b>Primase</b>
Elongation	<b>DNA polymerase III</b>	Elongation of fragment <b>DNA polymerase III</b>
Replacement of RNA primer by DNA	<b>DNA polymerase I</b>	Replacement of RNA primer by DNA <b>DNA polymerase I</b>
		Joining of fragments <b>Ligase</b>

---

---

---

---

---

---

---

---

---

---

## E. DNA Proofreading and Repair

- There is about about one error in  $10^6$  nucleotides bases added in DNA replication, repaired by: proofreading, mismatch repair, and excision repair.
- DNA repair mechanisms lower the error rate to about one base in  $10^9$ .

---

---

---

---

---

---

---

---

---

---

## Proofreading: 3' to 5'

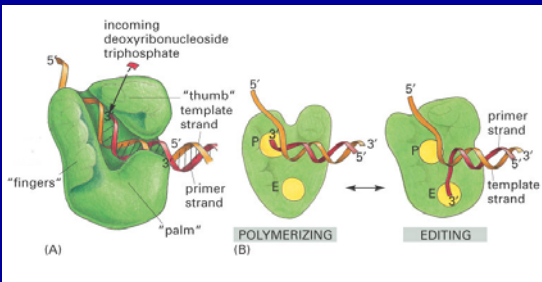

---

---

---

---

---

---

---

---

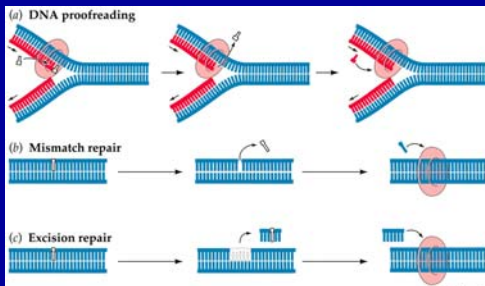

---

---

---

---

---

---

---

---

## E. DNA Proofreading and Repair

- Although energetically costly and somewhat redundant, DNA repair is crucial to the survival of the cell.

---

---

---

---

---

---

---

---



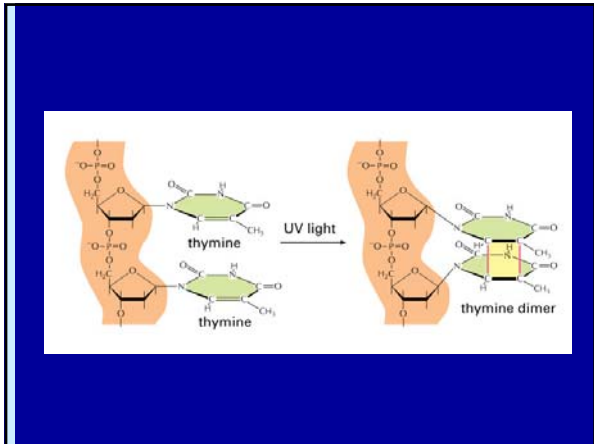

---

---

---

---

---

---

---

---

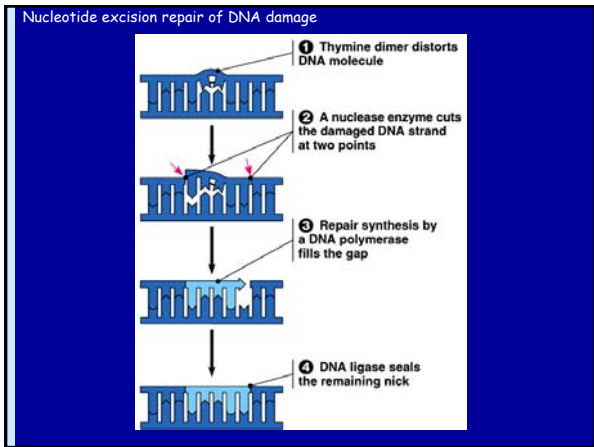

---

---

---

---

---

---

---

---

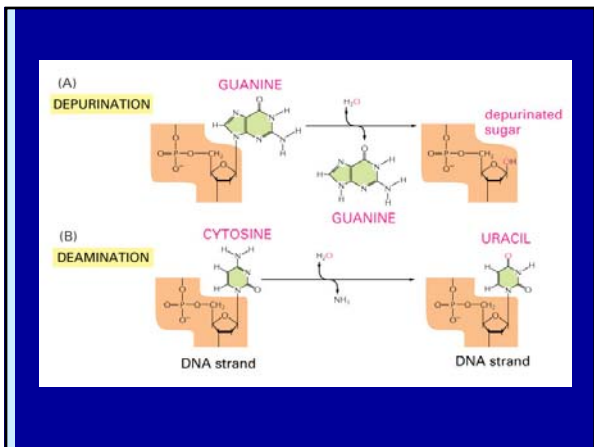

---

---

---

---

---

---

---

---

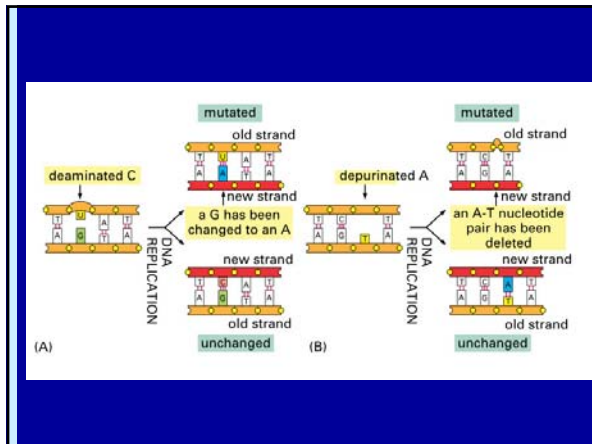

---

---

---

---

---

---

---

---

### E. DNA Proofreading and Repair

- Some moderately repetitive DNA sequences, such as telomeric DNA is found at the ends of chromosomes. Some may be lost during each DNA replication, leading to chromosome instability and cell death.
- Telomerase catalyzes the restoration of lost telomeric DNA.
- Most somatic cells lack telomerase and thus have limited life spans.

---

---

---

---

---

---

---

---

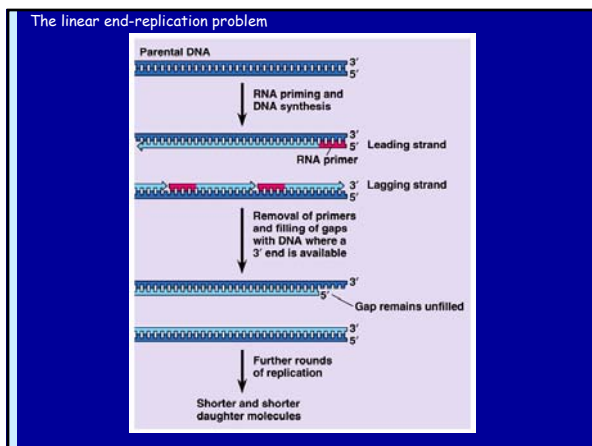

---

---

---

---

---

---

---

---

Telomeres and telomerase

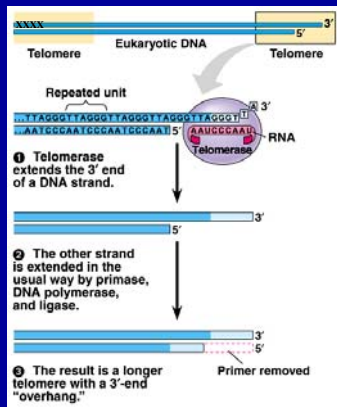

---

---

---

---

---

---

---

---

---

---

Telomeres (aka telomeric DNA)

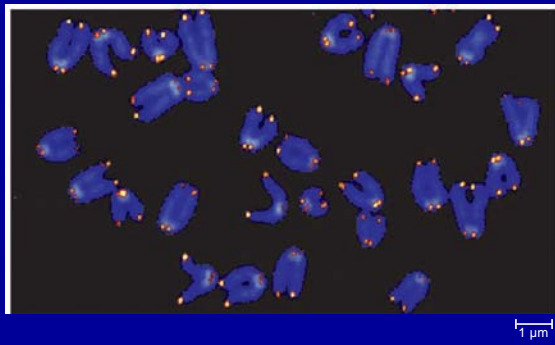

---

---

---

---

---

---

---

---

---

---

F. Practical Applications of DNA Replication

- The principles of DNA replication can be used to determine the nucleotide sequence of DNA.
- The polymerase chain reaction technique uses DNA polymerases to repeatedly replicate DNA in the test tube.

---

---

---

---

---

---

---

---

---

---

# DNA Sequencing

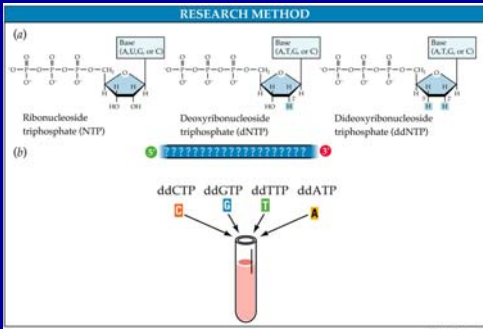

---

---

---

---

---

---

---

---

---

---

---

---

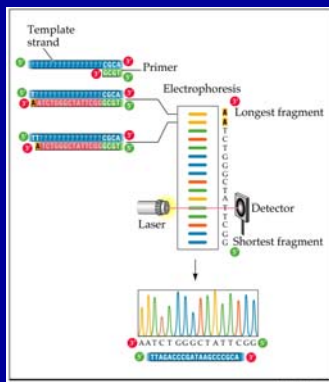

---

---

---

---

---

---

---

---

---

---

---

---

# Polymerase Chain Reaction: PCR

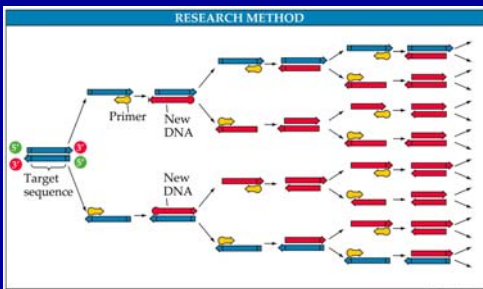

---

---

---

---

---

---

---

---

---

---

---

---