

Lecture Series 6
DNA and Its Role in Heredity

Reading Assignments

- Read Chapter 5
DNA and Chromosomes
- Read Chapter 6
DNA Replication, Repair & Replication
- Read Chapter 10
pages 331 to 333 & 347 to 351 2nd Edition
pages 340 to 343 & 345 to 347 3rd Edition
(Sections on Sequencing and PCR only)

A. DNA: The Genetic Material

- In addition to circumstantial evidence, three key experiments demonstrated that DNA is the genetic material.
- In the first key experiment (Griffiths, 1928) showed that a virulent strain of *Streptococcus pneumoniae*. genetically transformed nonvirulent *S. pneumoniae*. into virulent bacteria. Showed principle of "transformation".

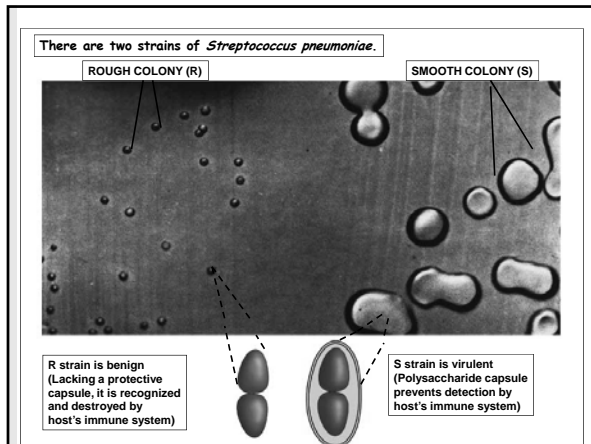

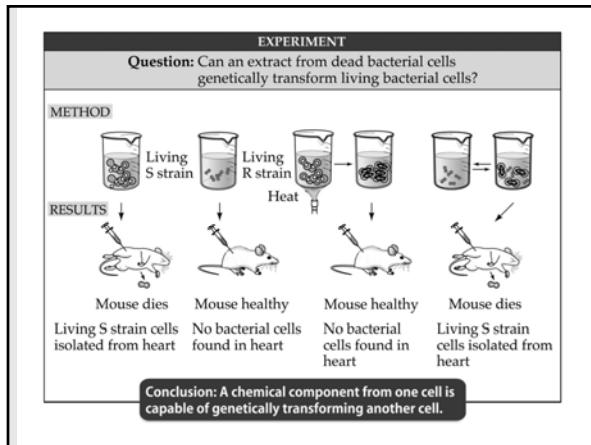

A. DNA: The Genetic Material

- The second key experiment (Avery, 1944) showed that "DNA" was the transforming agent through studies of T-even bacteriophage and their treatment with hydrolytic enzymes.
- The third key experiment (Hershey & Chase, 1952) showed that labeled viruses were incubated with host bacteria. Labeled viral DNA entered host cells, producing many label-bearing viruses. This confirmed DNA instead of proteins.

The Hershey-Chase Blender Experiment

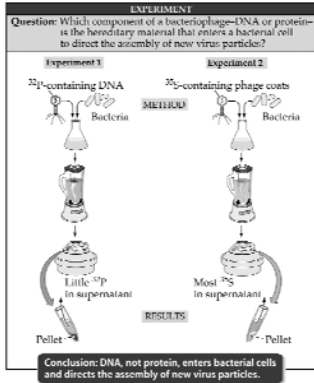

B. The Structure of DNA

- X-ray crystallography showed that the DNA molecule is a helix.

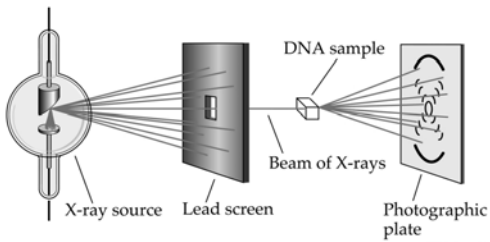

Rosalind Franklin and her X-ray diffraction photo of DNA

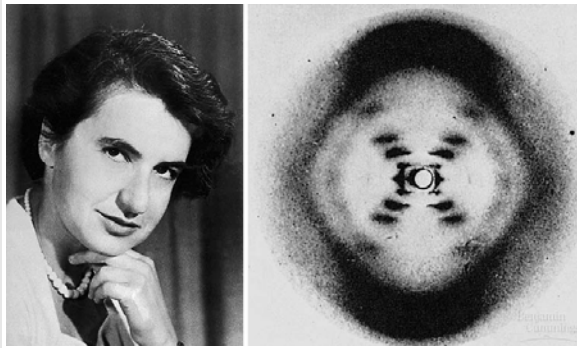

B. The Structure of DNA

- DNA is composed of nucleotides, each containing adenine, cytosine, thymine, or guanine.
- There are equal amounts of adenine and thymine and equal amounts of guanine and cytosine. This is known as Chargaff's Rule (1950, using paper TLC).

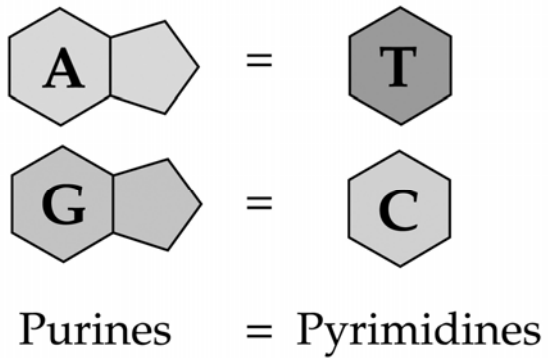

B. The Structure of DNA

- Watson and Crick (1953) proposed that DNA is a double-stranded helix with antiparallel strands, and with bases linked by hydrogen bonding.
- Their model accounts for genetic information, mutation, and replication functions of DNA.

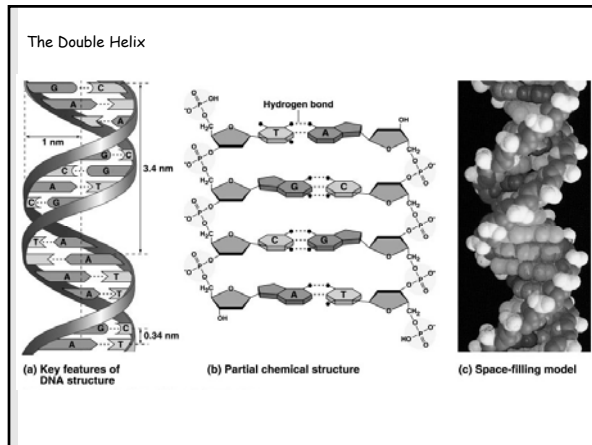

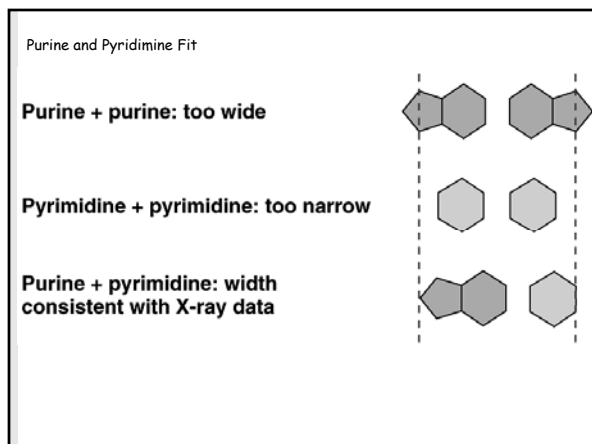

Watson and Crick and their Model

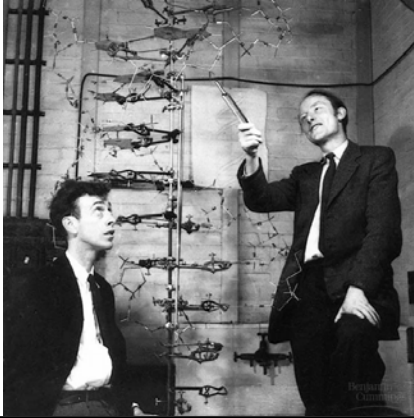

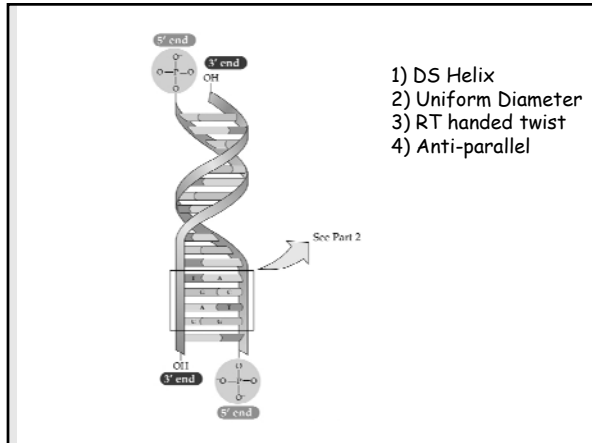

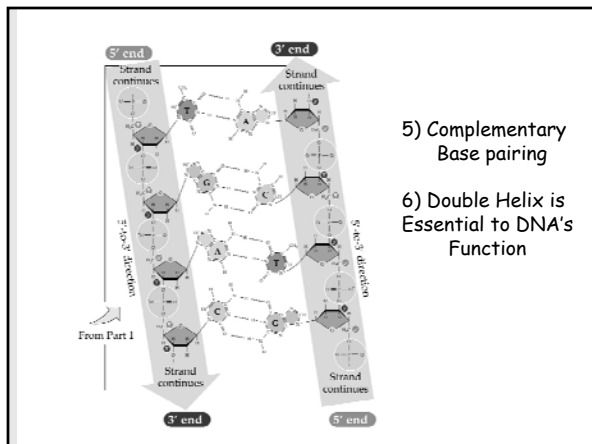

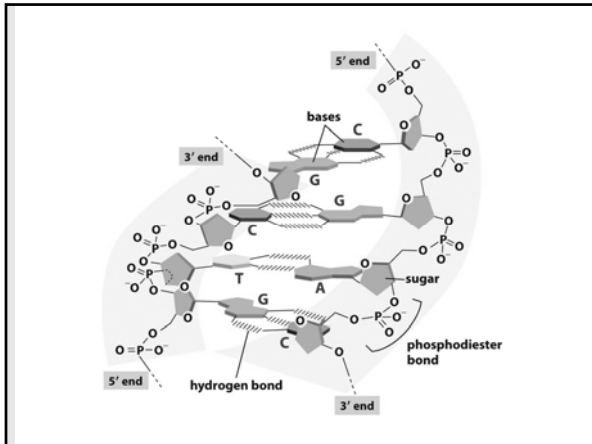

C. DNA Replication

- Semiconservative, conservative, and dispersive models for DNA replication were hypothesized.
- Each obeyed base-pairing rules.

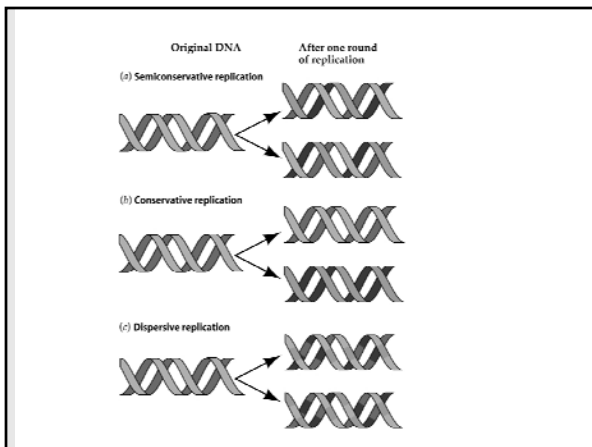

C. DNA Replication

- Kornberg (1956) demonstrated *in vitro* that DNA served as its own template during replication.
- Meselson and Stahl's experiment (1957) proved replication of DNA to be semiconservative. A parent strand is a template for synthesis of a new strand. Two replicated DNA helices contain one parent strand and one synthesized strand each.

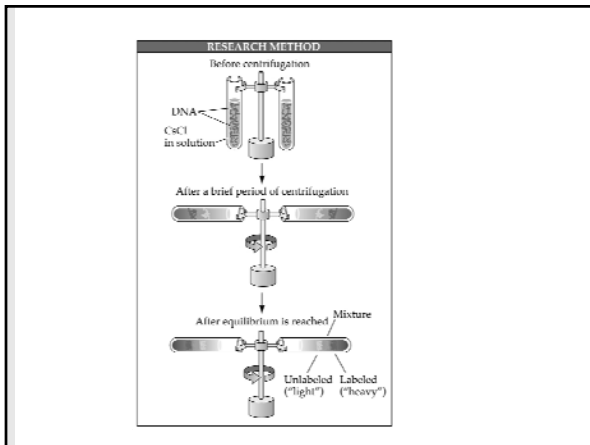

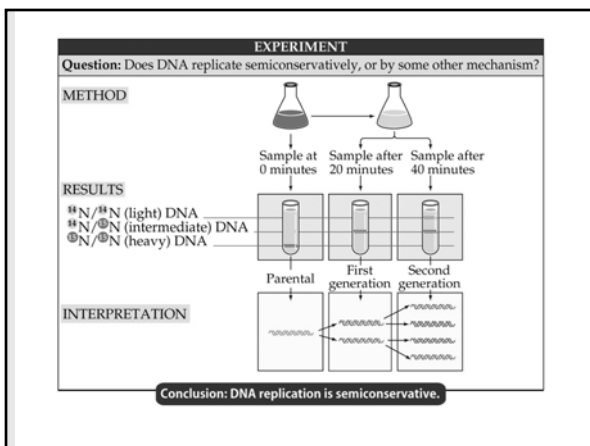

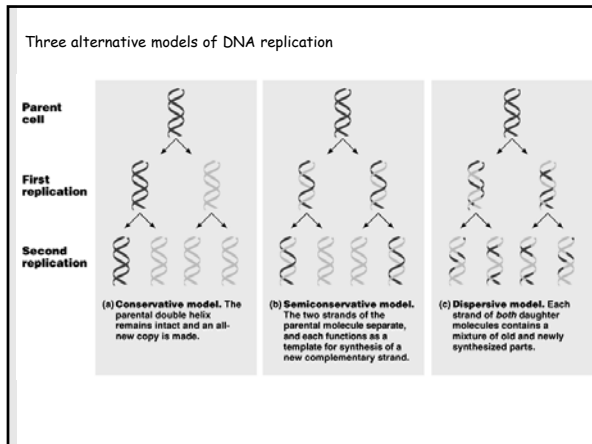

D. The Mechanism of DNA Replication

- DNA polymerase catalyzes nucleotides from the 5' to the 3' end.
- Nucleotides are added by complementary base pairing with the template strand.
- The substrates, deoxyribonucleoside triphosphates, are hydrolyzed as added, releasing energy for DNA synthesis.

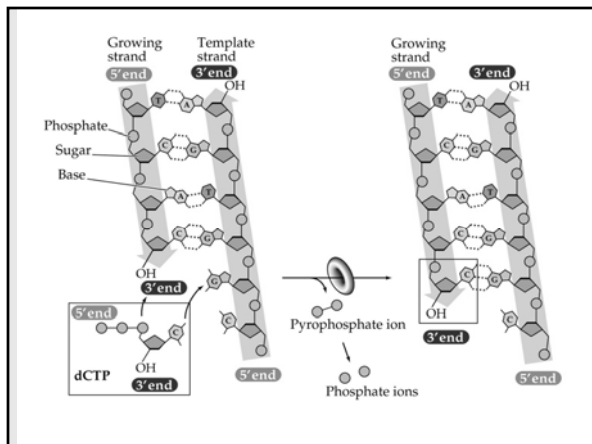

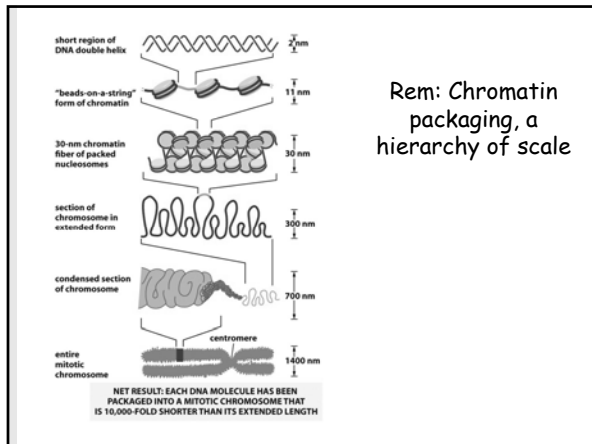

Rem: Chromatin packaging, a hierarchy of scale

D. The Mechanism of DNA Replication

- News Flash: The DNA replication complex is in a fixed location and DNA is threaded through it for replication.
- Old idea was via moving replication forks.

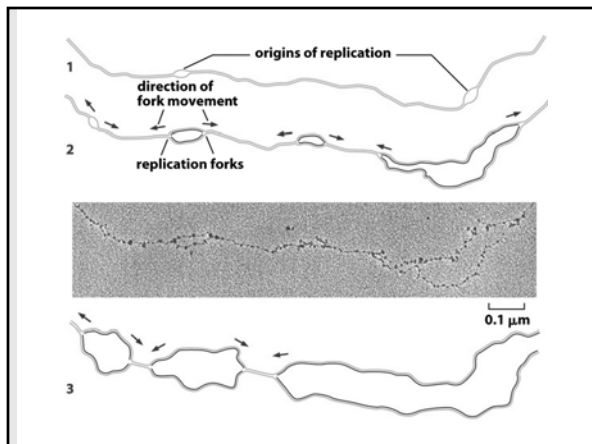

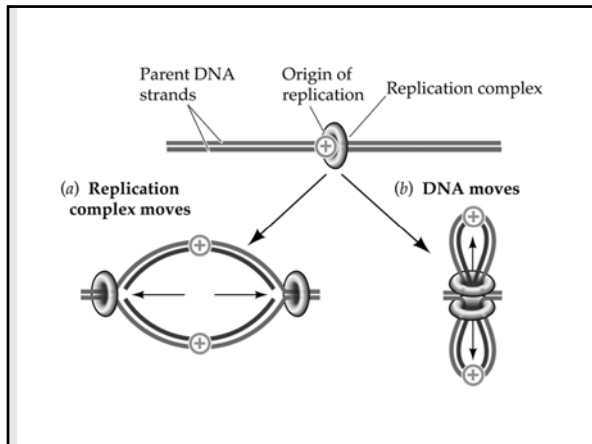

D. The Mechanism of DNA Replication

- Bacteria have a single origin of replication; eucaryotes have many (10^2 to 10^3).
- Replication for each proceeds in both directions from an origin of replication.

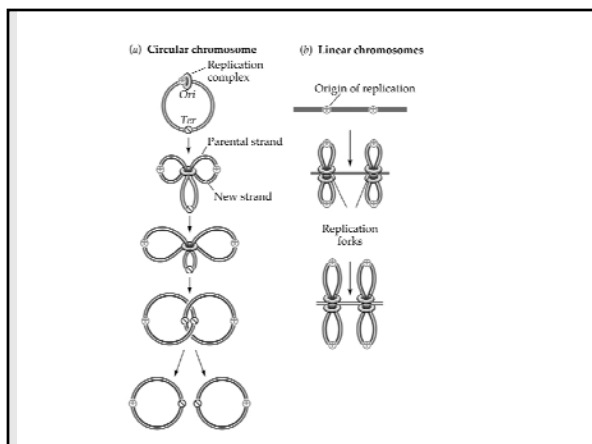

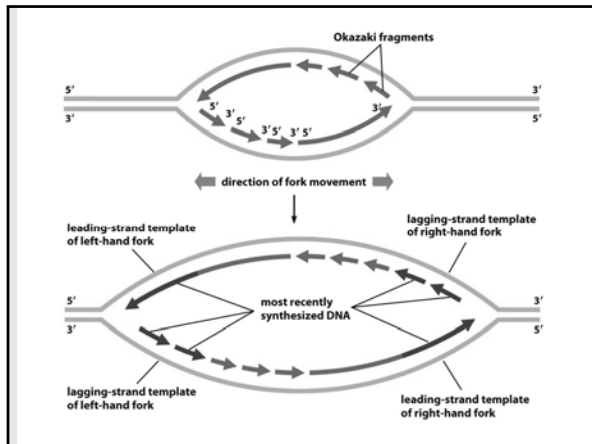

D. The Mechanism of DNA Replication

- Many proteins assist in DNA replication. DNA helicases unwind the double helix, the template strands are stabilized by single-stranded binding proteins.
- An RNA primase catalyzes the synthesis of short RNA primers, and to which nucleotides are added.

Enzymes for DNA replication: Primase

DNA Synthesis Requires a RNA Primer

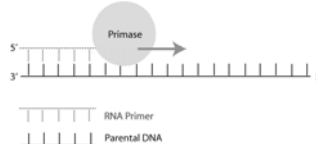

- Primase: provides a short, complementary strand of RNA that is required for DNA synthesis from a naked DNA template.
- There is no known DNA polymerase that can initiate synthesis of a DNA strand - they can only add nucleotides to a pre-existing strand.

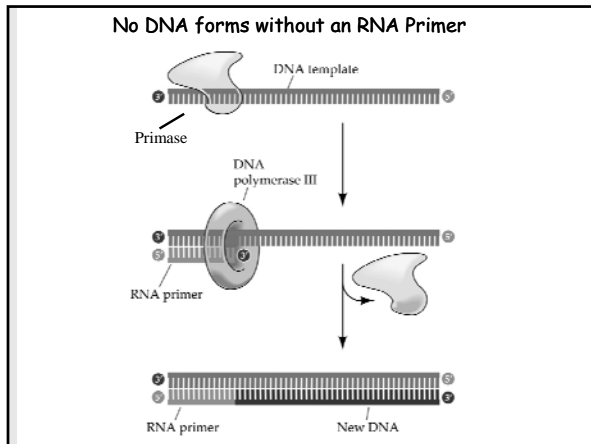

D. The Mechanism of DNA Replication

- DNA polymerase III action causes the leading strand to grow in the 5'-to-3' direction until replication of that section of DNA is complete.
- RNA primer is degraded and DNA is replaced by DNA polymerase I.

D. The Mechanism of DNA Replication

- On the lagging strand, growing in the other direction, DNA is made in the 5'-to-3' direction but synthesis is discontinuous: DNA is added as short Okazaki fragments to primers, then DNA polymerase III skips past the 5' end to make the next fragment.
- DNA polymerase I and Ligase are required to make lagging strand "continuous".

Many Proteins Collaborate at the Replication Fork

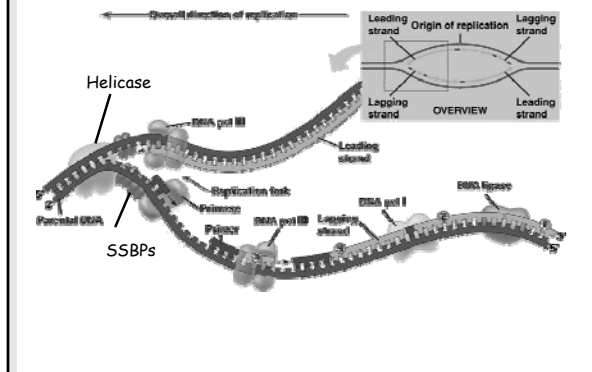

Two Daughter Strands form Different Ways

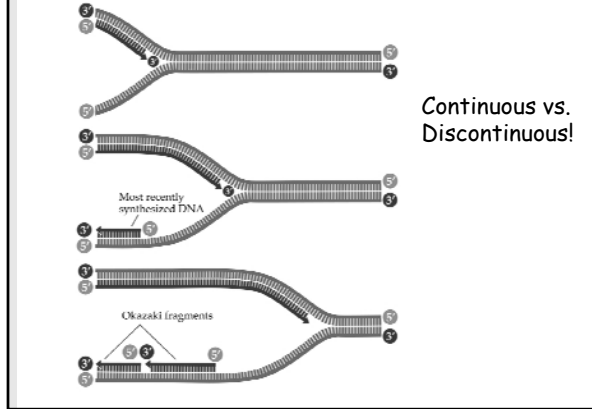

Finishing touches on the discontinuous or lagging strand

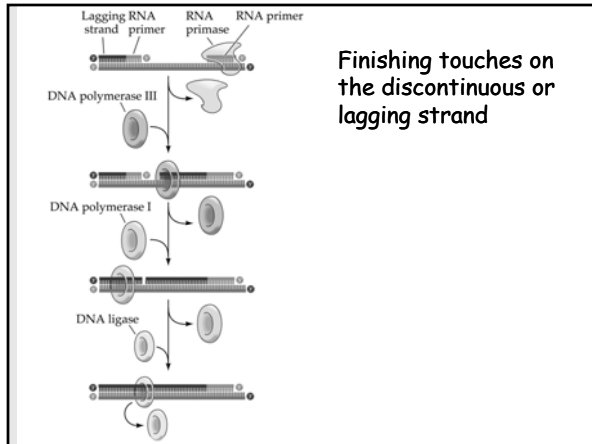

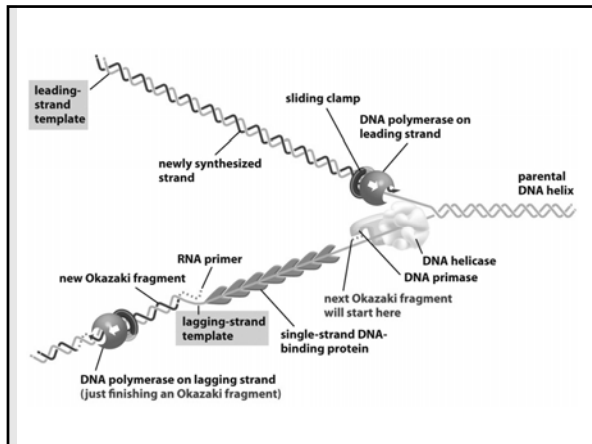

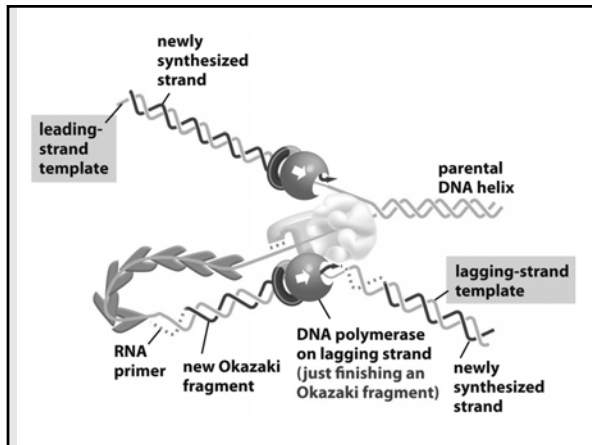

E. DNA Proofreading and Repair

- There is about about one error in 10^7 nucleotides bases added in DNA replication, repaired by: proofreading, mismatch repair, and excision repair.
- DNA repair mechanisms lower the error rate to about one base in 10^9 .

TABLE 6-1 ERROR RATES

US Postal Service on-time delivery of local first-class mail	13 late deliveries per 100 parcels
Airline luggage system	1 lost bag per 200
A professional typist typing at 120 words per minute	1 mistake per 250 characters
Driving a car in the United States	1 death per 10 ⁴ people per year
DNA replication (without mismatch repair)	1 mistake per 10 ⁷ nucleotides copied
DNA replication (including mismatch repair)	1 mistake per 10 ⁹ nucleotides copied

Proofreading: 3' to 5'

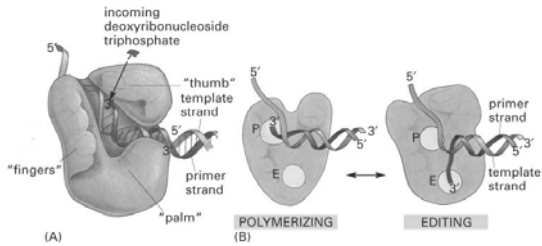

(a) DNA proofreading

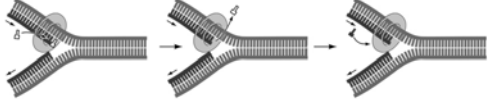

(b) Mismatch repair



(c) Excision repair



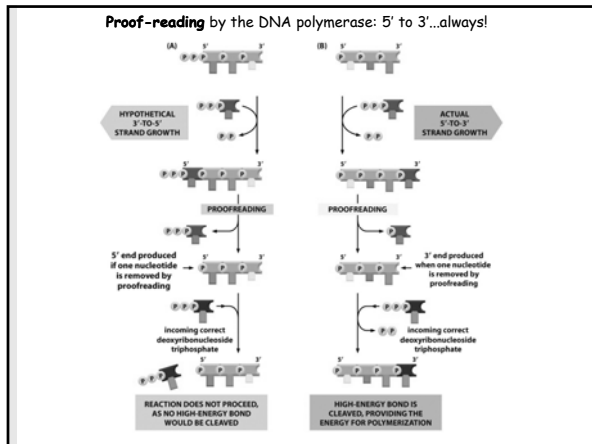

E. DNA Proofreading and Repair

- Although energetically costly and somewhat redundant, DNA repair is crucial to the survival of the cell.

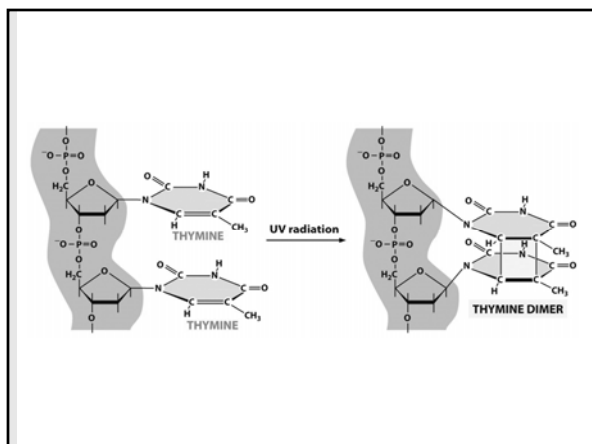

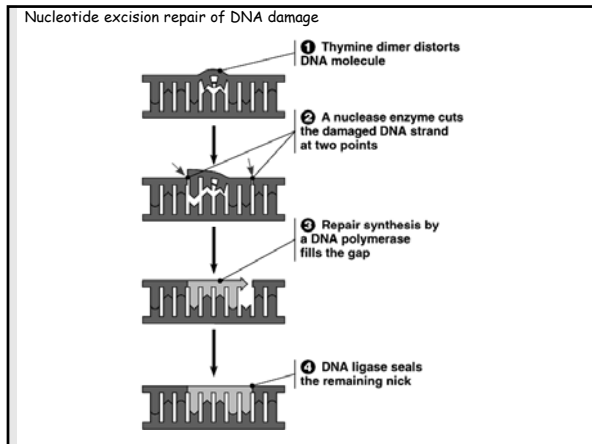

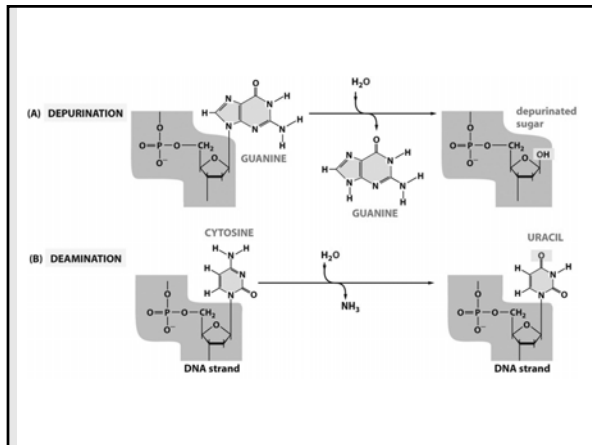

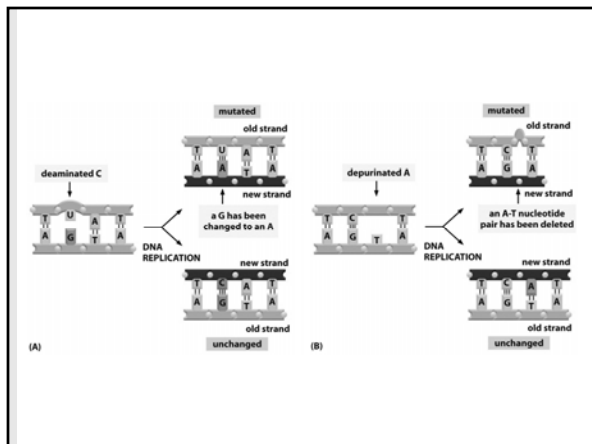

E. DNA Proofreading and Repair

- Some moderately repetitive DNA sequences, such as telomeric DNA is found at the ends of chromosomes. Some may be lost during each DNA replication, leading to chromosome instability and cell death.
- Telomerase catalyzes the restoration of lost telomeric DNA.
- Most somatic cells lack telomerase and thus have limited life spans.

The linear end-replication problem

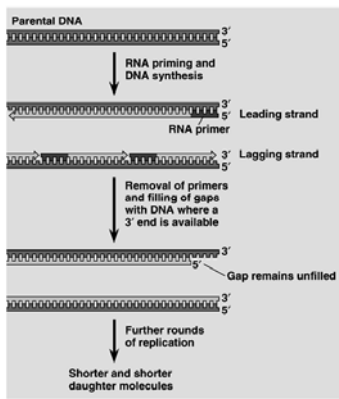

① DNA replication is initiated at the origin; the replication bubble grows as the two replication forks move in opposite directions.

② Finally only one primer (red) remains on each daughter DNA molecule.

③ The last primers are removed by a 5'→3' exonuclease, but no DNA polymerase can fill the resulting gaps because there is no 3' OH available to which a nucleotide can be added.

④ Each round of replication generates shorter and shorter DNA molecules.

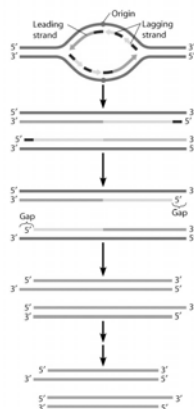

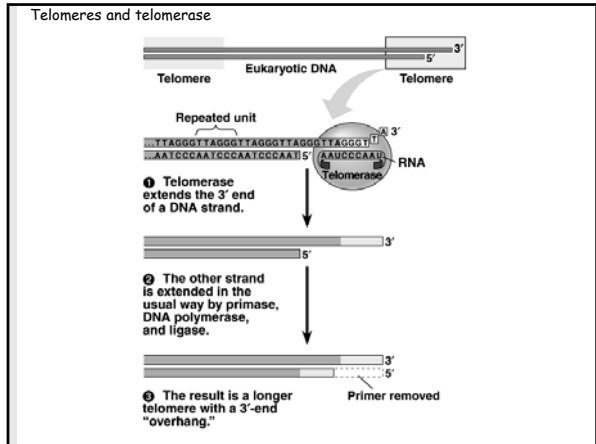

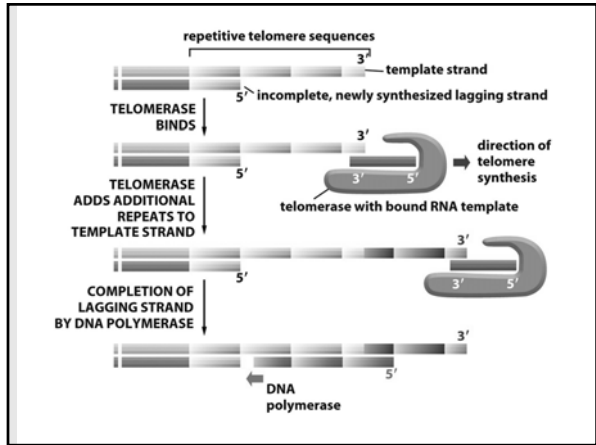

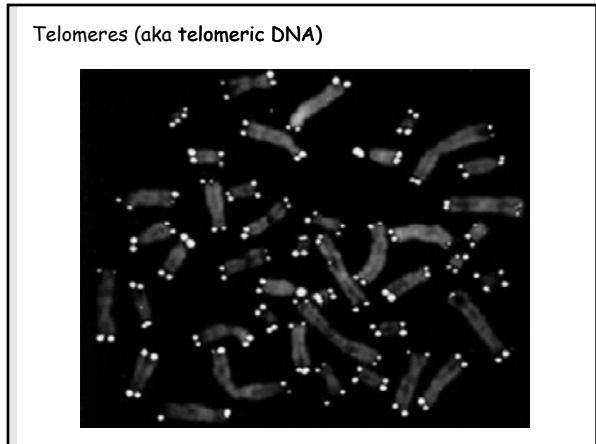

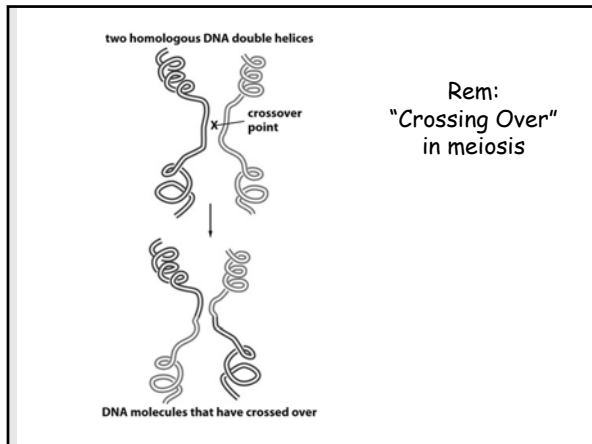

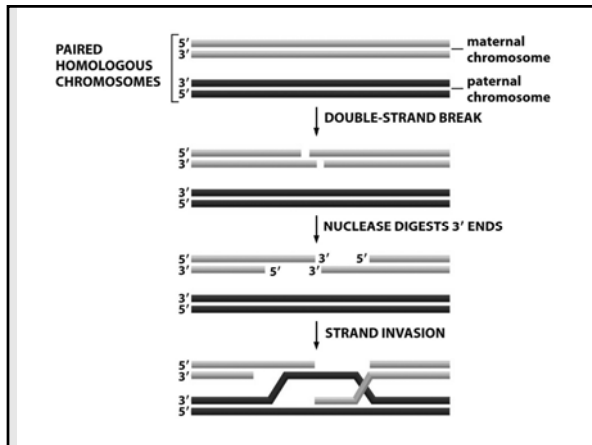

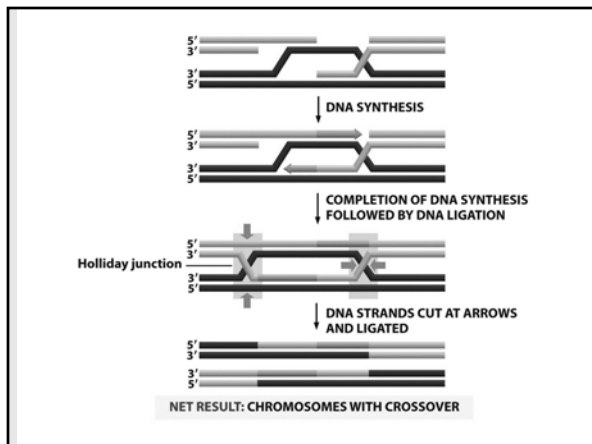

F. Practical Applications of DNA Replication

- The principles of DNA replication can be used to determine the nucleotide sequence of DNA.
- The polymerase chain reaction technique uses DNA polymerases to repeatedly replicate DNA in the test tube.

DNA Sequencing

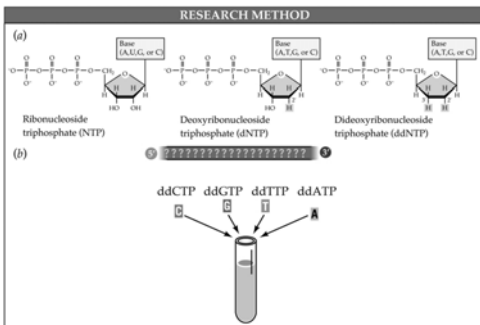

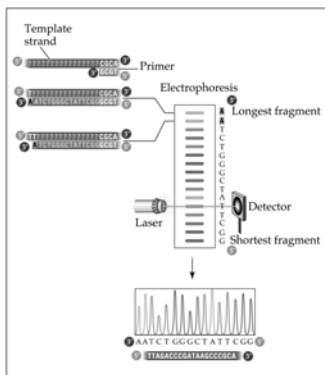

Polymerase Chain Reaction: PCR

