

Lecture Series 11
Cellular Pathways That Harvest Chemical Energy

Cellular Pathways That Harvest Chemical Energy

- A. Obtaining Energy and Electrons from Glucose
- B. An Overview: Releasing Energy from Glucose
- C. Glycolysis: From Glucose to Pyruvate
- D. Pyruvate Oxidation
- E. The Citric Acid Cycle

Cellular Pathways That Harvest Chemical Energy

- F. The Respiratory Chain: Electrons, Proton Pumping, and ATP
- G. Fermentation: ATP from Glucose, without O₂
- H. Contrasting Energy Yields
- I. Metabolic Pathways
- J. Regulating Energy Pathways

Cellular Pathways In General

- Metabolic pathways occur in small steps, each catalyzed by a specific enzyme.
- Metabolic pathways are often compartmentalized and are highly regulated.

A. Obtaining Energy and Electrons from Glucose

- When glucose burns, energy is released as heat and light:

$$C_6H_{12}O_6 + 6 O_2 \rightarrow 6 CO_2 + 6 H_2O + \text{energy}$$
- The same equation applies to the metabolism of glucose by cells, but the reaction is accomplished in many separate steps so that the energy can be captured as ATP with minimal loss as heat.

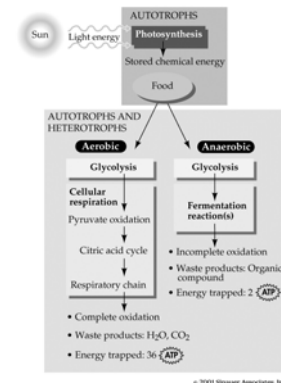
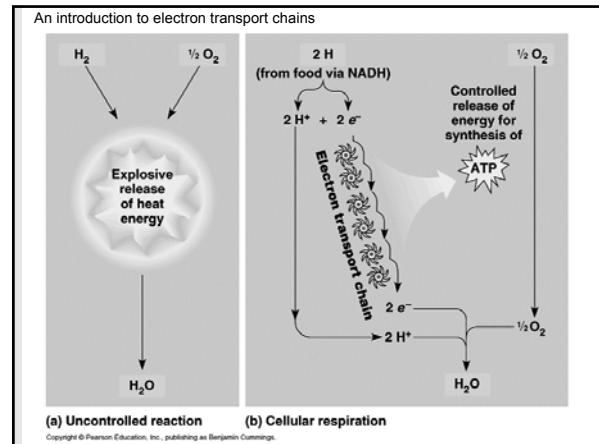
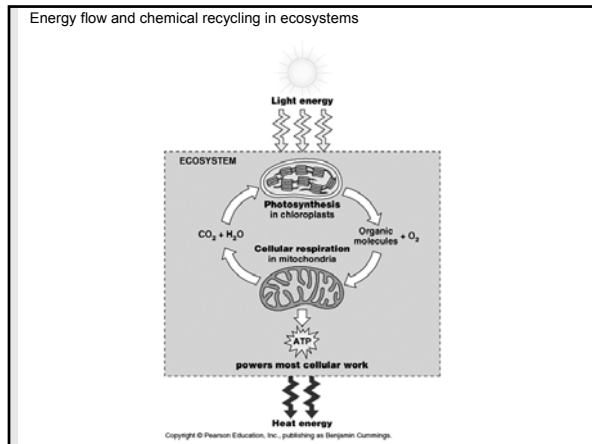
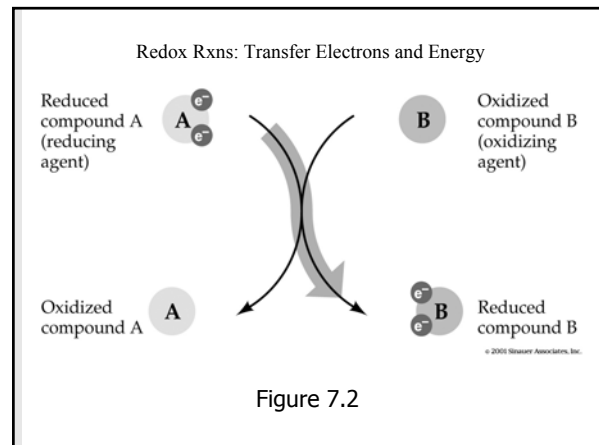

Figure 7.1



A. Obtaining Energy and Electrons from Glucose

- As a material is oxidized, the electrons it loses transfer to another material, which is thereby reduced.
- Such redox reactions transfer a lot of energy. Much of the energy liberated by the oxidation of the reducing agent is captured in the reduction of the oxidizing agent.



A. Obtaining Energy and Electrons from Glucose

- The coenzyme NAD is a key electron carrier in biological redox reactions.
- It exists in two forms, one oxidized (NAD⁺) and the other reduced (NADH + H⁺).

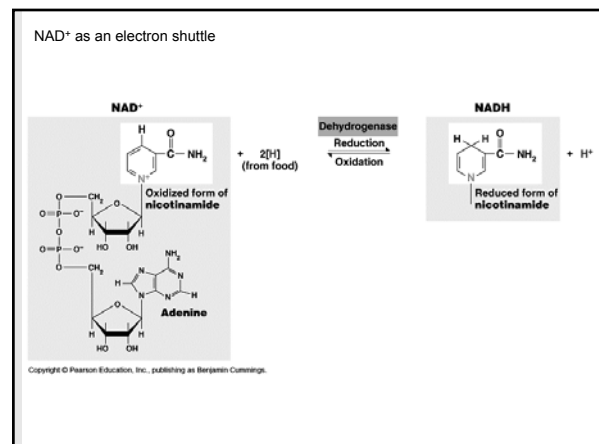

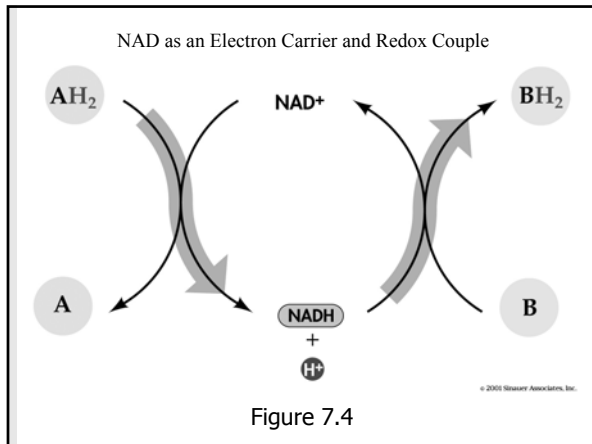

C. An Overview: Releasing Energy from Glucose

- Glycolysis operates in the presence or absence of O_2 .
- Under aerobic conditions, cellular respiration continues the breakdown process.

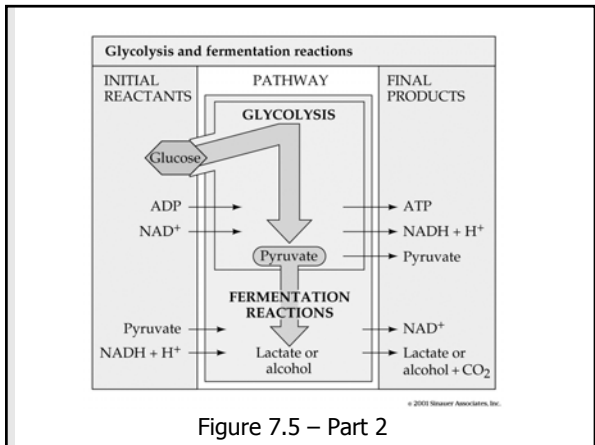
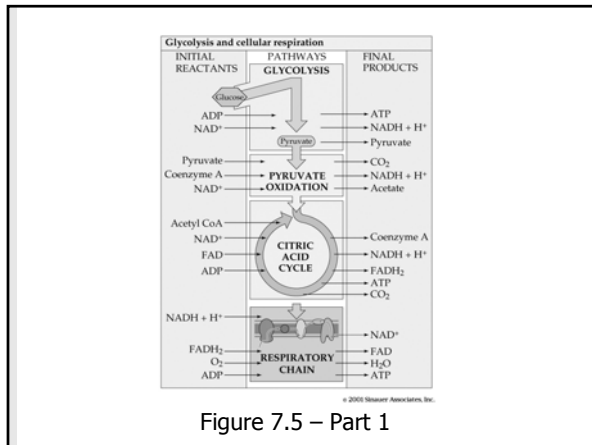

B. An Overview: Releasing Energy from Glucose

- Pyruvate oxidation and the citric acid cycle produce CO_2 and hydrogen atoms carried by NADH and $FADH_2$.
- The respiratory chain combines the hydrogens with O_2 , releasing enough energy for additional ATP synthesis.

B. An Overview: Releasing Energy from Glucose

- In some cells under anaerobic conditions, pyruvate can be reduced by NADH to form lactate and regenerate the NAD needed to sustain glycolysis.
- This is called a fermentation.

B. An Overview: Releasing Energy from Glucose

- In eukaryotes, glycolysis and fermentation occur in the cytoplasm outside of the mitochondria; pyruvate oxidation, the citric acid cycle, and the respiratory chain operate in association with mitochondria.
- In prokaryotes, glycolysis, fermentation, and the citric acid cycle take place in the cytoplasm; and pyruvate oxidation and the respiratory chain operate in association with the plasma membrane.

7.1 Cellular Locations for Energy Pathways in Eukaryotes and Prokaryotes

EUKARYOTES	PROKARYOTES
External to mitochondrion	In cytoplasm
Glycolysis	Glycolysis
Fermentation	Fermentation
	Citric acid cycle
Inside mitochondrion	On inner face of plasma membrane
Inner membrane	Pyruvate oxidation
Pyruvate oxidation	Respiratory chain
Respiratory chain	
Matrix	
Citric acid cycle	

Table 7.1

C. Glycolysis: From Glucose to Pyruvate

- Glycolysis is a pathway of ten enzyme-catalyzed reactions located in the cytoplasm.
- It provides starting materials for both cellular respiration and fermentation.

C. Glycolysis: From Glucose to Pyruvate

- The energy-investing reactions of glycolysis use two ATPs per glucose molecule and eventually yield two glyceraldehyde 3-phosphate molecules.
- In the energy-harvesting reactions, two NADH molecules are produced, and four ATP molecules are generated by substrate-level phosphorylation.
- Two pyruvates are produced for each glucose molecule.

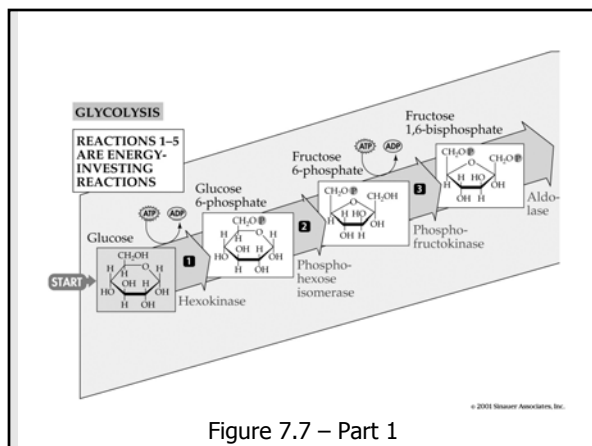

Figure 7.7 – Part 1

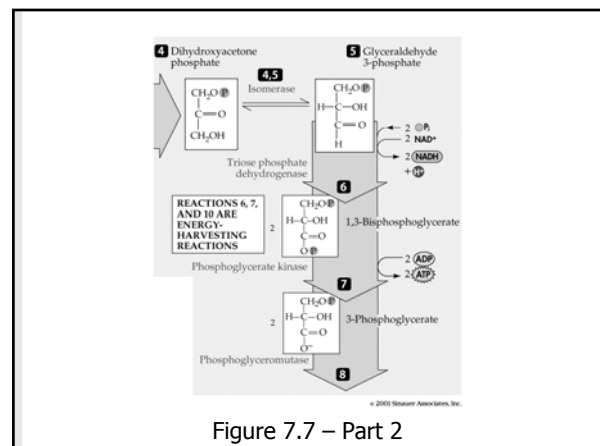
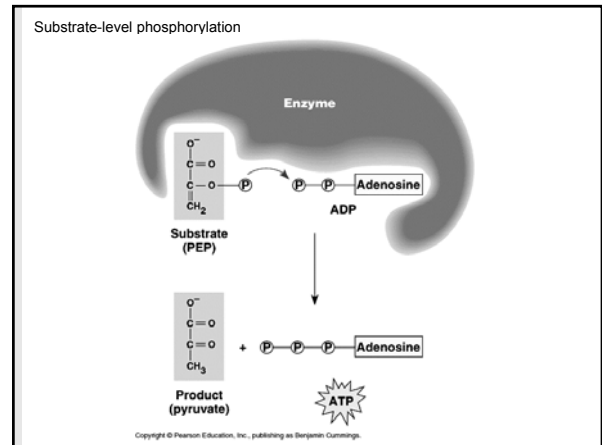
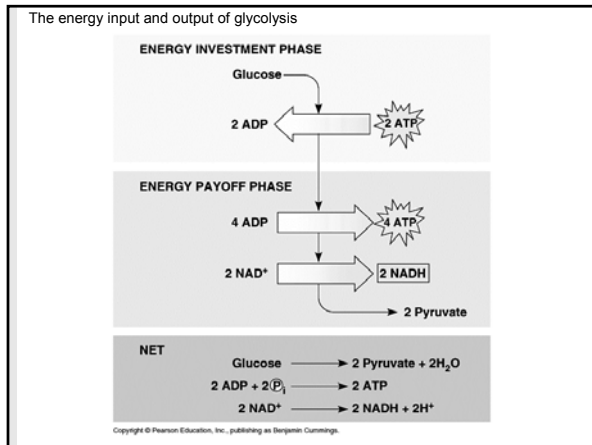
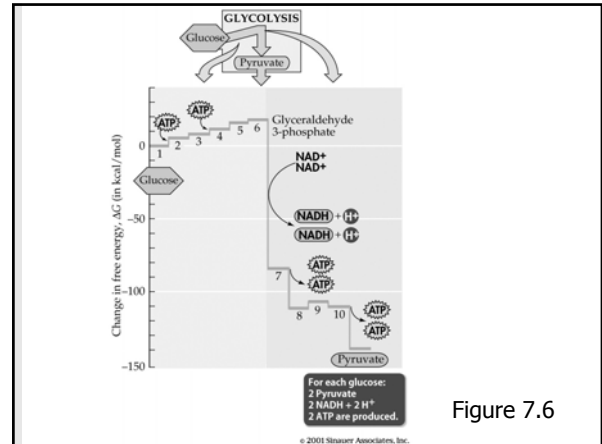
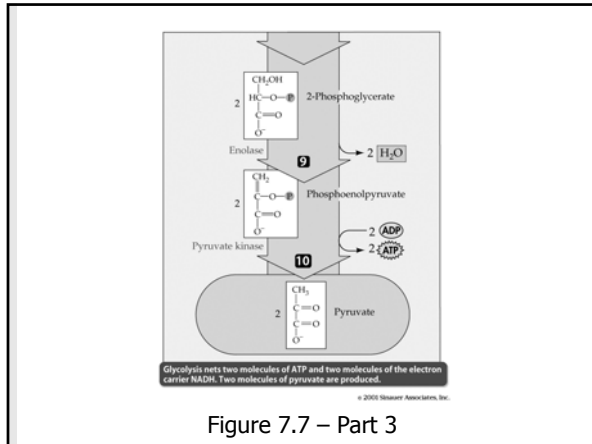
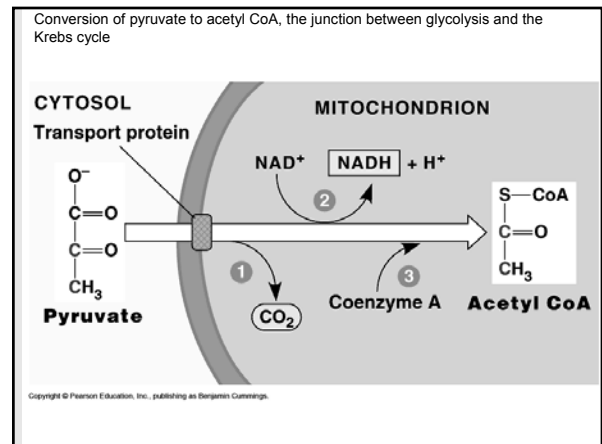

Figure 7.7 – Part 2



D. Pyruvate Oxidation

- The pyruvate dehydrogenase complex catalyzes three reactions:
- (1) Pyruvate is oxidized to the acetyl group, releasing one CO₂ molecule and energy;
- (2) some of this energy is captured when NAD⁺ is reduced to NADH + H⁺; and
- (3) the remaining energy is captured when the acetyl group combines with coenzyme A, yielding acetyl CoA.



E. The Citric Acid Cycle

- The energy in acetyl CoA drives the reaction of acetate with oxaloacetate to produce citrate.
- The citric acid cycle is a series of reactions in which citrate is oxidized and oxaloacetate regenerated.
- It produces two CO_2 , one FADH_2 , three NADH , and one ATP for each acetyl CoA.

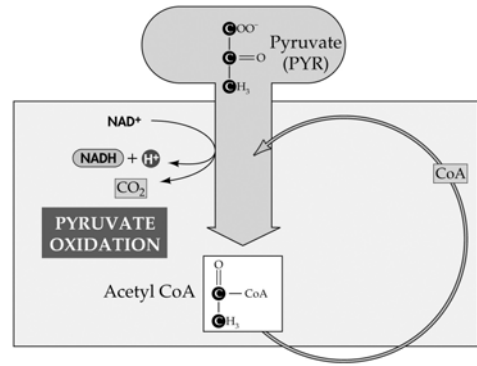

Figure 7.9 – Part 1

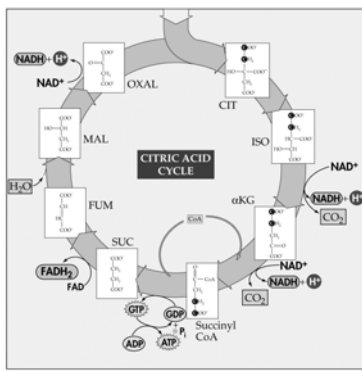

Figure 7.9 – Part 2

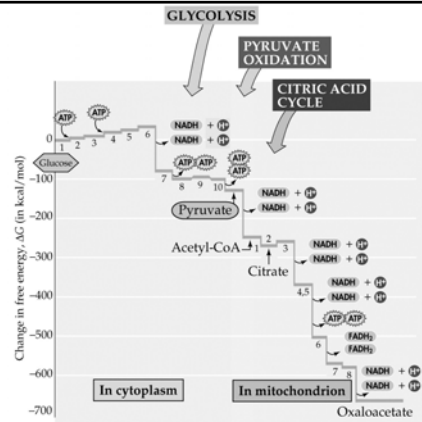
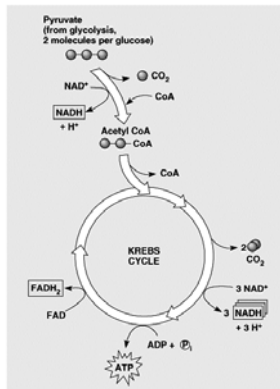

Figure 7.10

A summary of the Krebs cycle



F. The Respiratory Chain: Electrons, Proton Pumping, and ATP

- $\text{NADH} + \text{H}^+$ and FADH_2 from glycolysis, pyruvate oxidation, and the citric acid cycle are oxidized by the respiratory chain, regenerating NAD^+ and FAD .
- Most of the enzymes and other electron carriers of the chain are part of the inner mitochondrial membrane.
- O_2 is the final acceptor of electrons and protons, forming H_2O .

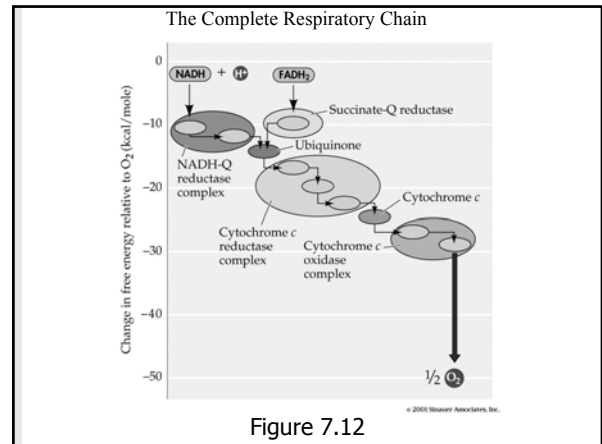
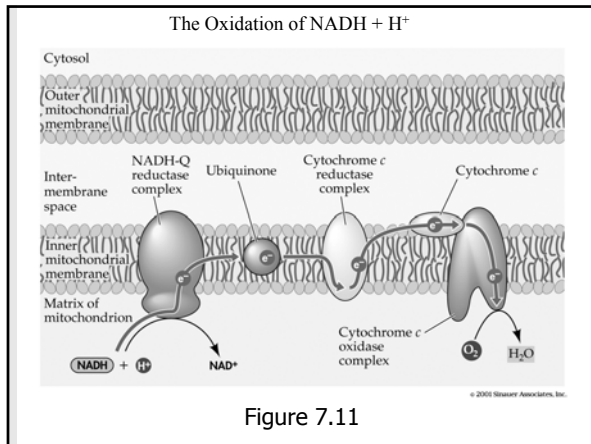

F. The Respiratory Chain: Electrons, Proton Pumping, and ATP

- The chemiosmotic mechanism couples proton transport to oxidative phosphorylation.
- As the electrons move along the respiratory chain, they lose energy, captured by proton pumps that actively transport H⁺ out of the mitochondrial matrix, establishing a gradient of proton concentration and electric charge—the proton-motive force or PMF.

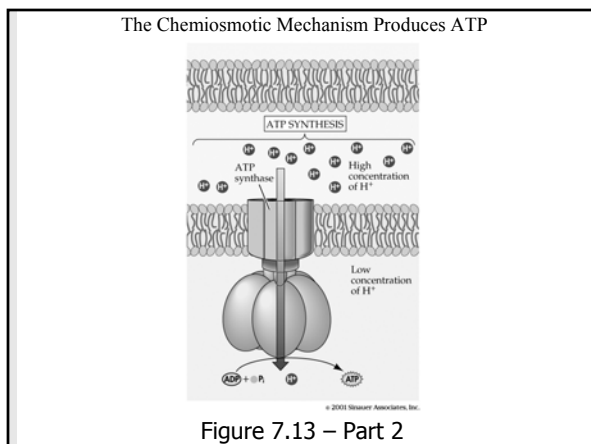
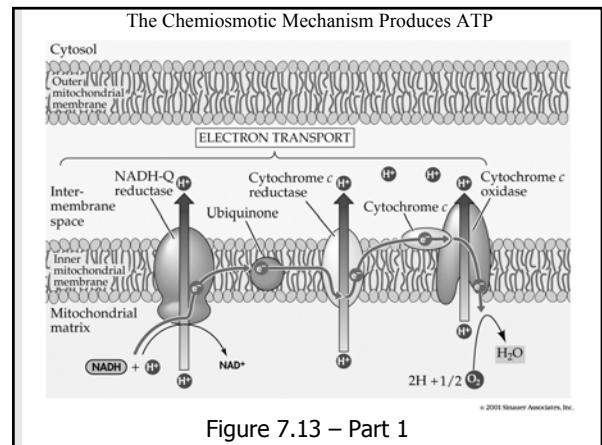

F. The Respiratory Chain: Electrons, Proton Pumping, and ATP

- The proton-motive force causes protons to diffuse back into the mitochondrial interior through the membrane channel protein ATP synthase, which couples that diffusion to the production of ATP.
- Several key experiments demonstrate that it is chemiosmosis that produces ATP.

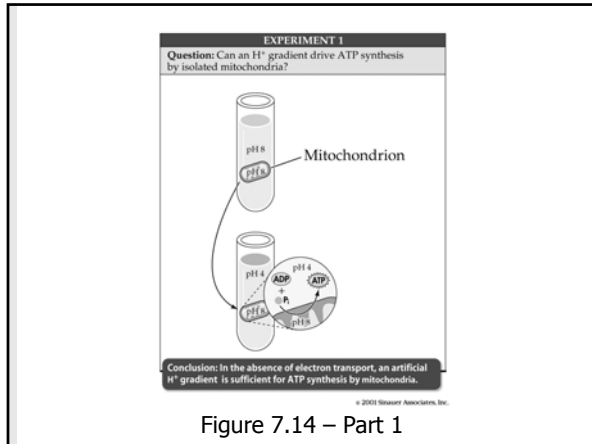

Figure 7.14 – Part 1

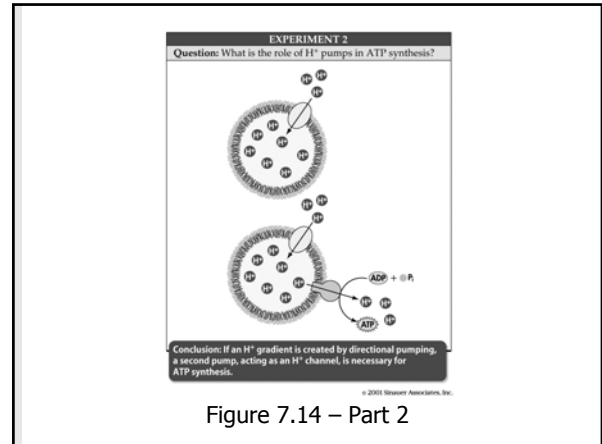
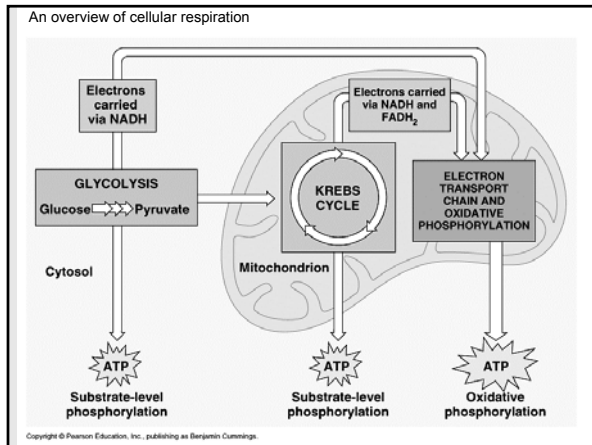
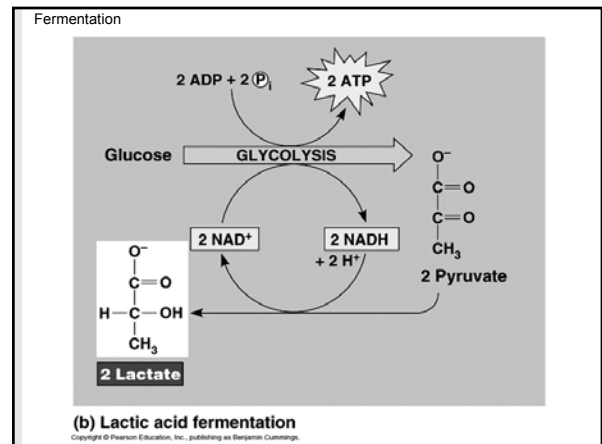
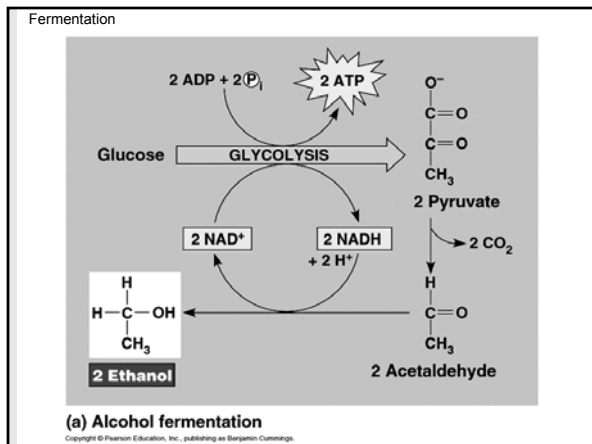

Figure 7.14 – Part 2



G. Fermentation: ATP from Glucose, without O_2

- Many organisms and some cells live without O_2 , deriving energy from glycolysis and fermentation.
- Together, these pathways partly oxidize glucose and generate energy-containing products.
- Fermentation reactions anaerobically oxidize the $NADH + H^+$ produced in glycolysis.



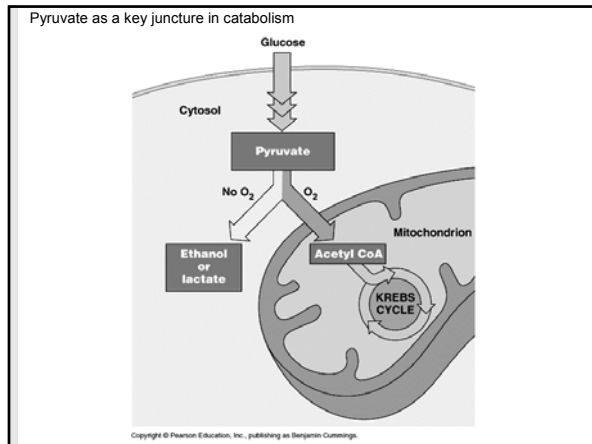

H. Contrasting Energy Yields

- For each molecule of glucose used, fermentation yields 2 molecules of ATP.
- In contrast, glycolysis operating with pyruvate oxidation, the citric acid cycle, and the respiratory chain yields up to 36 or 38.

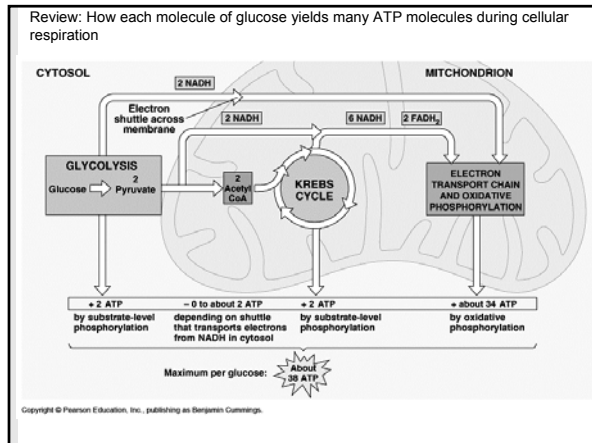

I. Metabolic Pathways

- Catabolic pathways feed into the respiratory pathways.
- Polysaccharides are broken down into glucose, which enters glycolysis.
- Glycerol from fats also enters glycolysis, and acetyl CoA from fatty acid degradation enters the citric acid cycle.
- Proteins enter glycolysis and the citric acid cycle via amino acids.

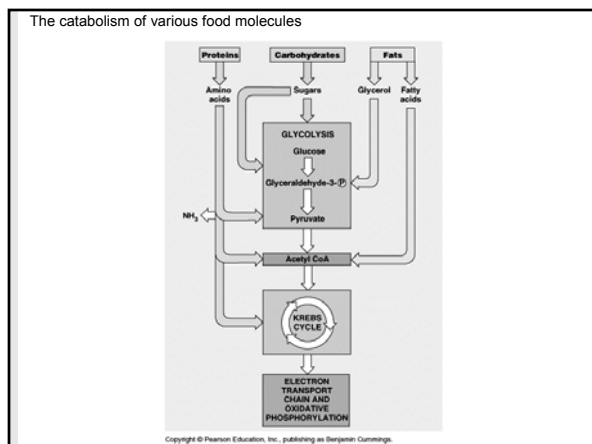

I. Metabolic Pathways

- Anabolic pathways use intermediate components of respiratory metabolism to synthesize fats, amino acids, and other essential building blocks for cellular structure and function.

J. Regulating Energy Pathways

- The rates of glycolysis and the citric acid cycle are increased or decreased by the actions of ATP, ADP, NAD⁺, or NADH + H⁺ on allosteric enzymes.
- Evolution has led to metabolic efficiency.

J. Regulating Energy Pathways

- Inhibition of the glycolytic enzyme phosphofructokinase by abundant ATP from oxidative phosphorylation slows glycolysis. ADP activates this enzyme, speeding up glycolysis.
- The citric acid cycle enzyme isocitrate dehydrogenase is inhibited by ATP and NADH and activated by ADP and NAD⁺.
- Citrate also inhibits PFK.

