

Lecture Series 7 DNA and Its Role in Heredity

DNA and Its Role in Heredity

- A. [DNA: The Genetic Material](#)
- B. [The Structure of DNA](#)
- C. [DNA Replication](#)
- D. [The Mechanism of DNA Replication](#)
- E. [DNA Proofreading and Repair](#)
- F. [Practical Applications of DNA Replication](#)

A. DNA: The Genetic Material

- In addition to circumstantial evidence, two key experiments demonstrated that DNA is the genetic material.
- In the first key experiment (Griffiths, 1928) showed that a virulent strain of *Streptococcus pneumoniae* genetically transformed nonvirulent *S. pneumoniae* into virulent bacteria.

There are two strains of *Streptococcus pneumoniae*.

ROUGH COLONY (R)

SMOOTH COLONY (S)

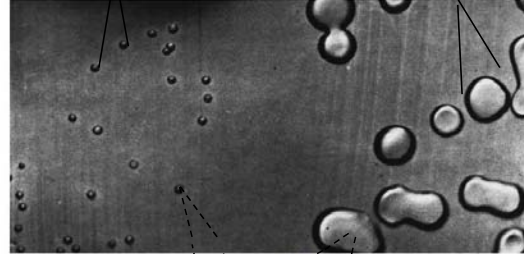

R strain is benign
(Lacking a protective capsule, it is recognized and destroyed by host's immune system)

S strain is virulent
(Polysaccharide capsule prevents detection by host's immune system)

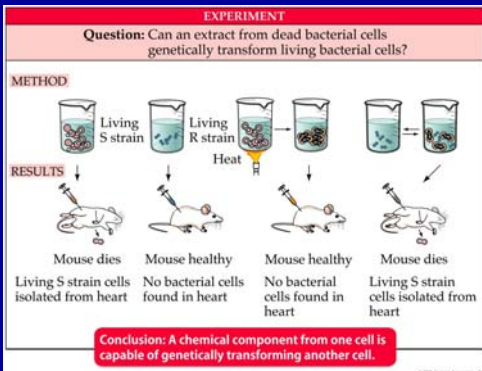
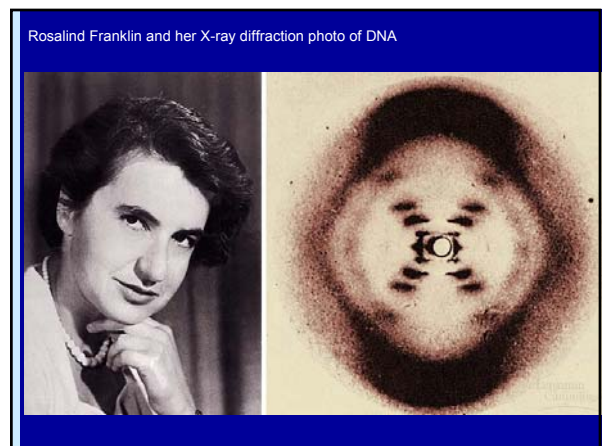
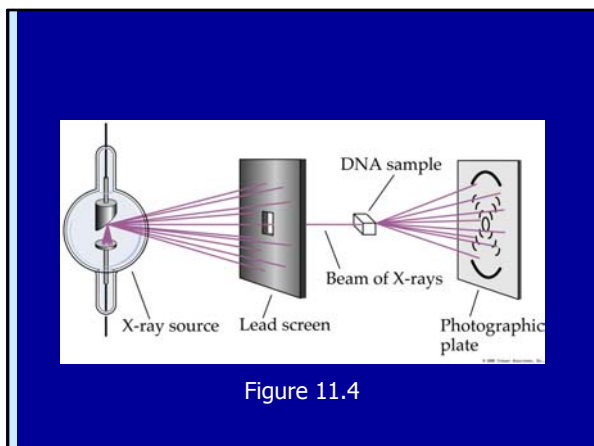
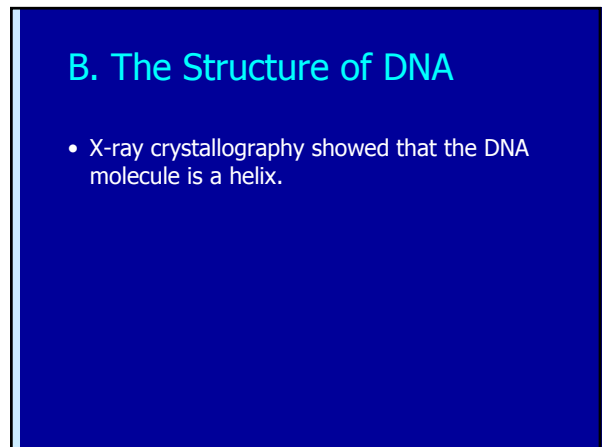
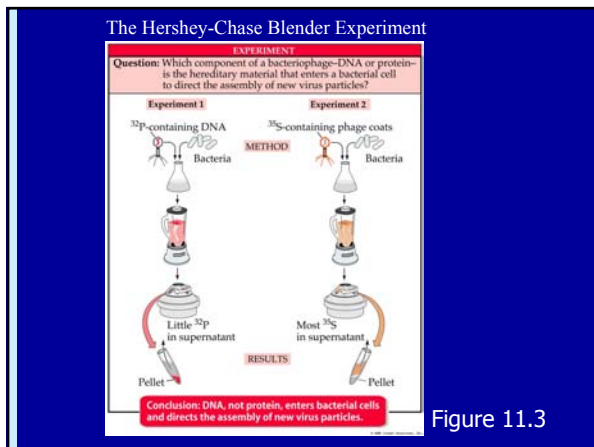
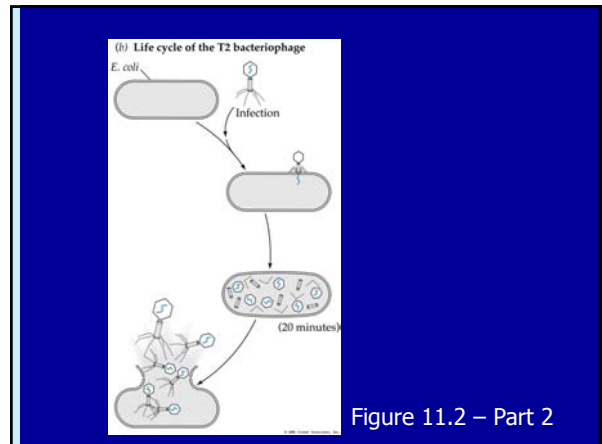
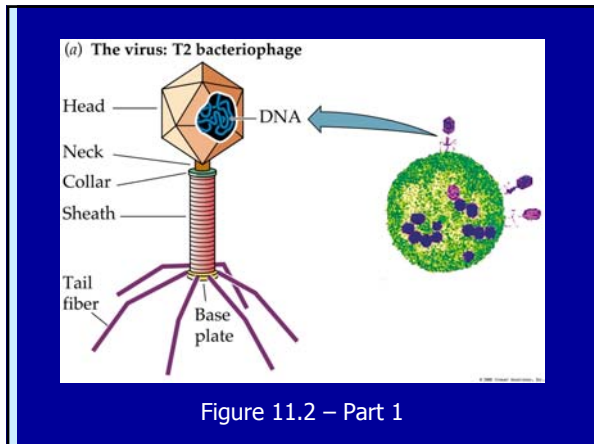

Figure 11.1

A. DNA: The Genetic Material

- In a prelude to the second key experiment (Avery, 1944) showed that DNA was the transforming agent through studies of T-even bacteriophage and their treatment with hydrolytic enzymes.
- The second key experiment (Hershey & Chase, 1952) showed that labeled viruses were incubated with host bacteria. Labeled viral DNA entered host cells, producing many label-bearing viruses.



B. The Structure of DNA

- DNA is composed of nucleotides, each containing adenine, cytosine, thymine, or guanine.
- There are equal amounts of adenine and thymine and equal amounts of guanine and cytosine. This is known as Chargaff's Rule (1950, using paper TLC).

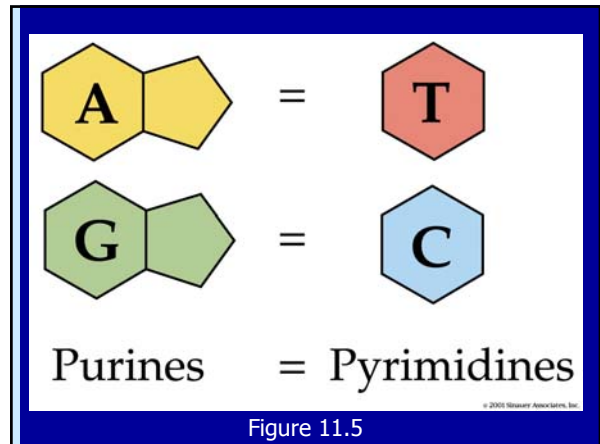

B. The Structure of DNA

- Watson and Crick (1953) proposed that DNA is a double-stranded helix with antiparallel strands, and with bases linked by hydrogen bonding.
- Their model accounts for genetic information, mutation, and replication functions of DNA.

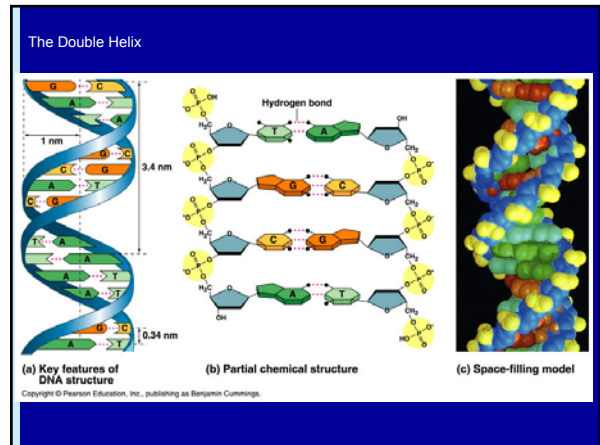

Purine and Pyrimidine Fit

Purine + purine: too wide



Pyrimidine + pyrimidine: too narrow



Purine + pyrimidine: width consistent with X-ray data



Copyright © Pearson Education, Inc., publishing as Benjamin Cummings.

Watson and Crick and their Model

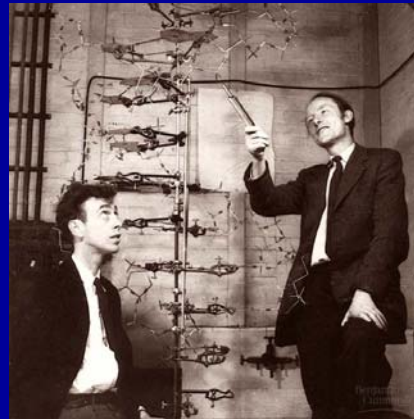

1) DS Helix
2) Uniform Diameter
3) RT handed twist
4) Anti-parallel

Figure 11.7 - Part 1

5) Complementary Base pairing
6) Double Helix is Essential to DNA's Function

Figure 11.7 – Part 2

C. DNA Replication

- Semiconservative, conservative, and dispersive models for DNA replication were hypothesized.
- Each obeyed base-pairing rules.

Figure 11.8

C. DNA Replication

- Kornberg (1956) demonstrated *in vitro* that DNA served as its own template during replication.
- Meselson and Stahl's experiment (1957) proved replication of DNA to be semiconservative. A parent strand is a template for synthesis of a new strand. Two replicated DNA helices contain one parent strand and one synthesized strand each.

Figure 11.9

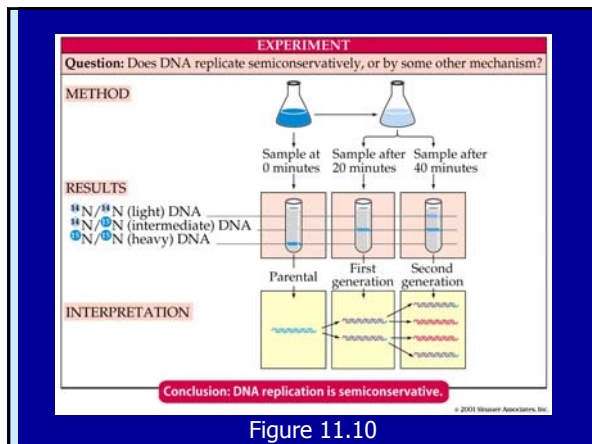
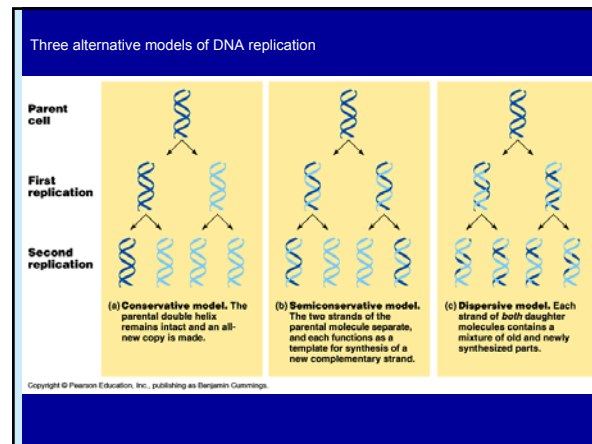

Figure 11.10



D. The Mechanism of DNA Replication

- DNA polymerase catalyzes nucleotides from the 5' to the 3' end.
- Nucleotides are added by complementary base pairing with the template strand.
- The substrates, deoxyribonucleoside triphosphates, are hydrolyzed as added, releasing energy for DNA synthesis.

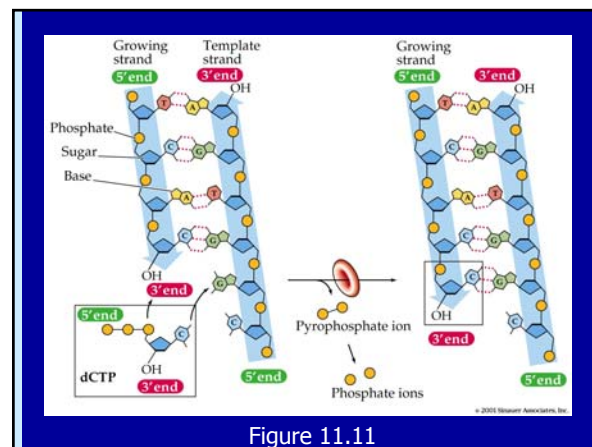

Figure 11.11

D. The Mechanism of DNA Replication

- News Flash: The DNA replication complex is in a fixed location and DNA is threaded through it for replication.
- Old idea was via moving replication forks.

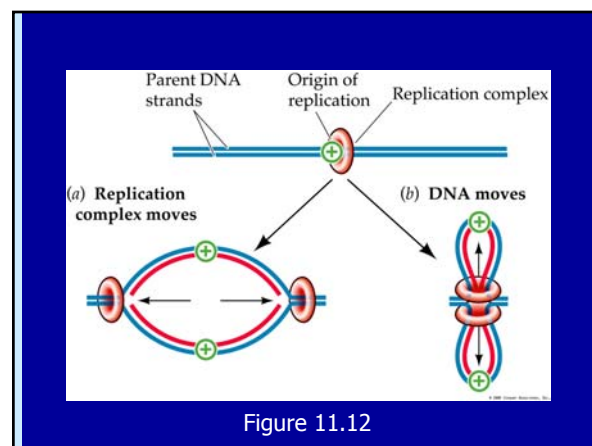

Figure 11.12

D. The Mechanism of DNA Replication

- Prokaryotes have a single origin of replication; eukaryotes have many (10^2 to 10^3).
- Replication for each proceeds in both directions from an origin of replication.

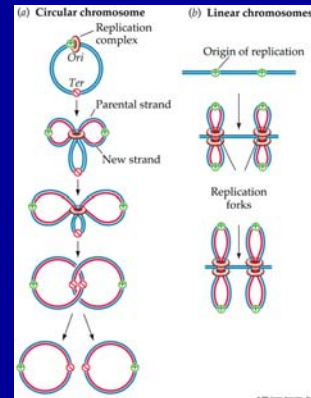

Figure 11.13

D. The Mechanism of DNA Replication

- Many proteins assist in DNA replication. DNA helicases unwind the double helix, the template strands are stabilized by single-stranded binding proteins.
- An RNA primase catalyzes the synthesis of short RNA primers, and to which nucleotides are added.

No DNA forms without an RNA Primer.

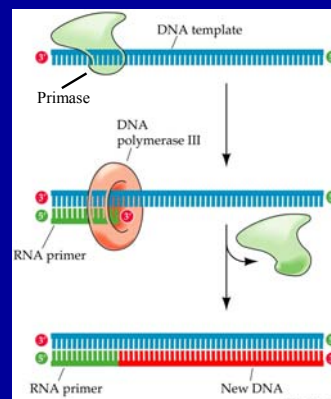

Figure 11.15

D. The Mechanism of DNA Replication

- DNA polymerase III action causes the leading strand to grow in the 5'-to-3' direction until replication of that section of DNA is complete.
- RNA primer is degraded and DNA is replaced by DNA polymerase I.

D. The Mechanism of DNA Replication

- On the lagging strand, growing in the other direction, DNA is made in the 5'-to-3' direction but synthesis is discontinuous: DNA is added as short Okazaki fragments to primers, then DNA polymerase III skips past the 5' end to make the next fragment.
- DNA polymerase I and Ligase are required to make lagging strand "continuous".

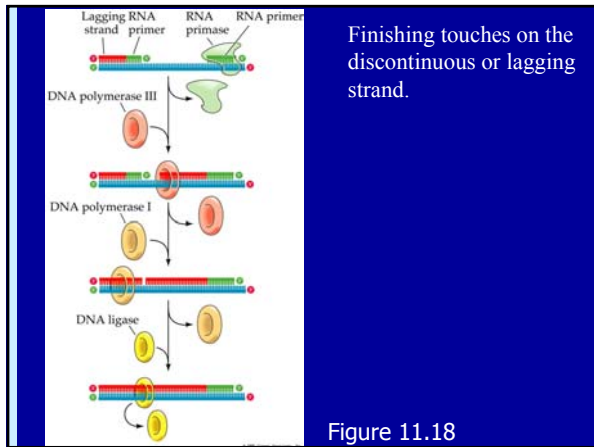
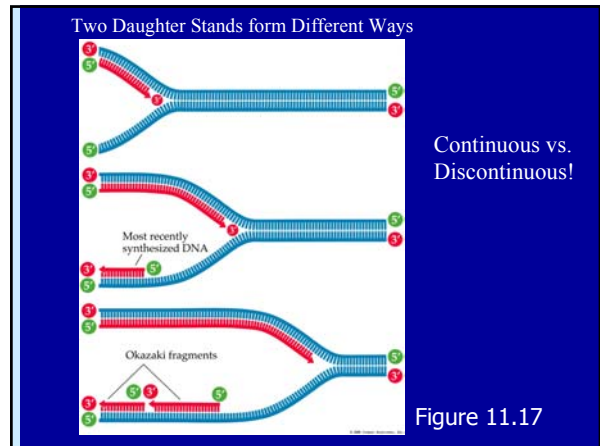
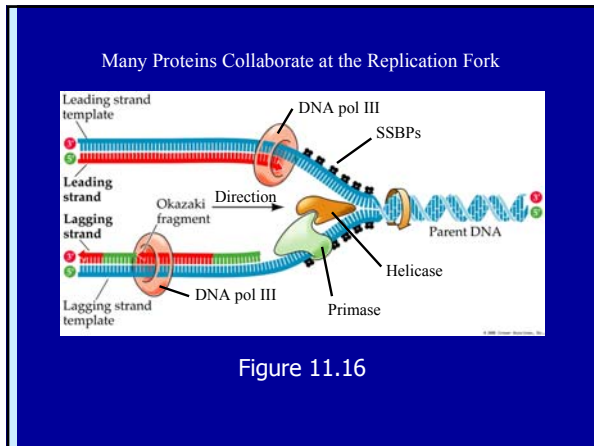

The main proteins of DNA replication and their functions

Initiation of replication			
Double helix unwinds, providing single-stranded DNA templates		Helicases and single-strand binding proteins	
Synthesis of leading strand		Synthesis of lagging strand	
Priming	Primase	Priming for Okazaki fragment	Primase
Elongation	DNA polymerase III	Elongation of fragment	DNA polymerase III
Replacement of RNA primer by DNA	DNA polymerase I	Replacement of RNA primer by DNA	DNA polymerase I
		Joining of fragments	Ligase

Copyright © Pearson Education, Inc., publishing as Benjamin Cummings.

E. DNA Proofreading and Repair

- There is about one error in 10^6 nucleotides bases added in DNA replication, repaired by: proofreading, mismatch repair, and excision repair.
- DNA repair mechanisms lower the error rate to about one base in 10^9 .

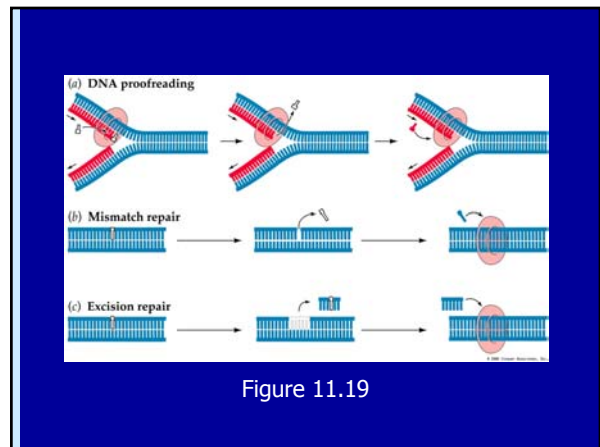

E. DNA Proofreading and Repair

- Although energetically costly and somewhat redundant, DNA repair is crucial to the survival of the cell.

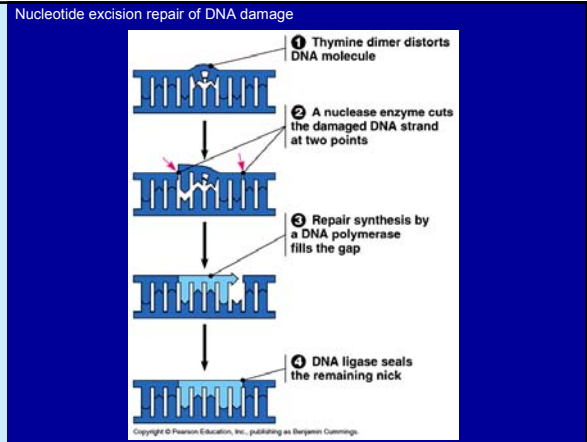

F. Practical Applications of DNA Replication

- The principles of DNA replication can be used to determine the nucleotide sequence of DNA.
- The polymerase chain reaction technique uses DNA polymerases to repeatedly replicate DNA in the test tube.

DNA Sequencing

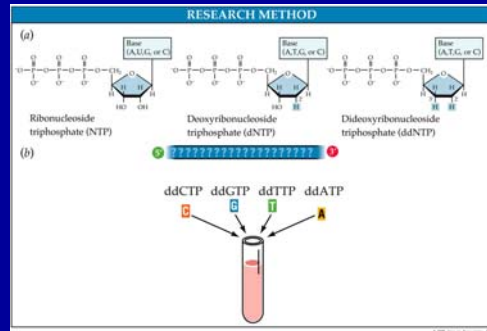

Figure 11.20 – Part 1

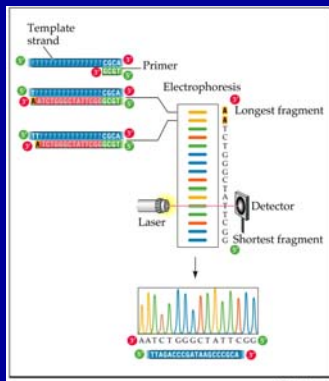

Figure 11.20 – Part 2

Polymerase Chain Reaction: PCR

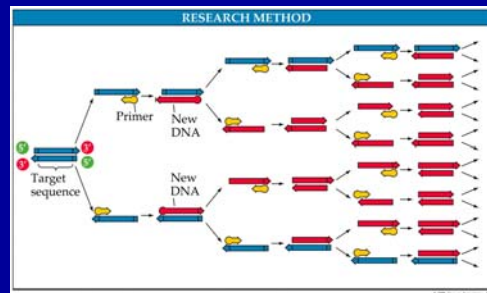

Figure 11.21